



A Group Company of **HILTI**

FRP COMPOSITE PRODUCTS

COMPLETE FRP/GRP SUPPORT SYSTEM

Support, Cable Ladders, Cable Trays and Accessories

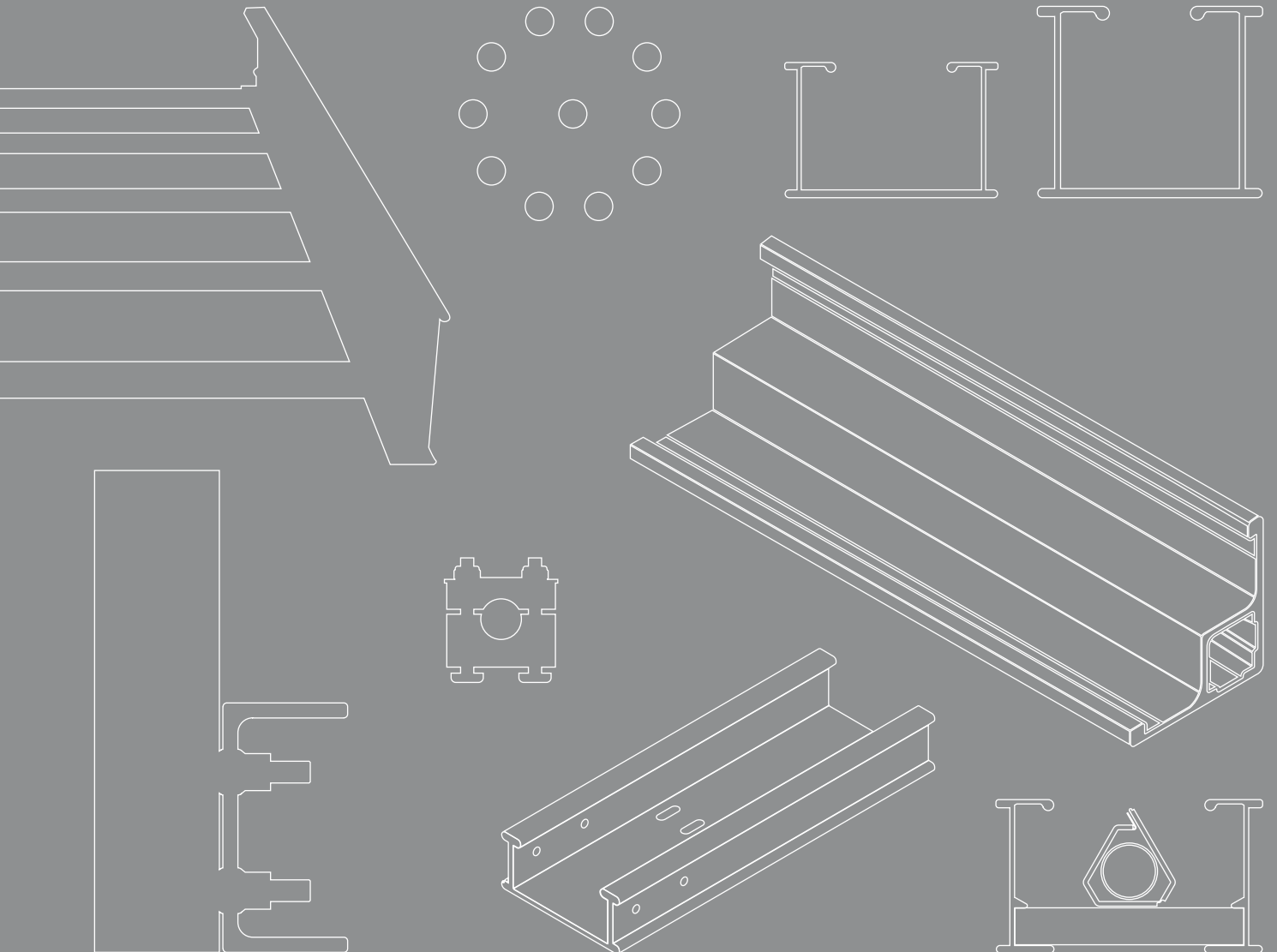

How to use

A generous range of our most popular standard products, from complete multi-discipline support systems to the smallest of fasteners can be identified and detailed using the information in the following chapters. The featured product ranges are offered based on decades of experience and our best practice solutions. They include ranges approved under DNV-GL, ABS, UL, CSA & RMRS schemes.

This Product Catalogue has been split into convenient sections covering the main product ranges we are proud to offer. Each section is preceded by a short introduction to the range, and contains important and useful information on how to identify the products from the type descriptions and product names. We invite you to preview these pages in order to maximise your experience of the offering. Our products are all illustrated for easy identification, and detailed by type descriptions, type names and article numbers. We have also included the weights in order that considerations can be made for build weight and most importantly for HSE.

Product information online

We have chosen to store all supporting documentation for our products online such as detailed dimension drawings, loading limitations, user guides, best practice guides and much more. This product catalogue feature our most popular systems and components. However, we also have a massive range of variants which are not featured. Should you require solutions different from those offered, or require any further information, please do not hesitate to contact us. Visit oglaend-system.com/products for more product information.

How to read type descriptions

We use a system of letters and numbers in our type descriptions to enable efficient identification of product properties.

Example: FOE70 FE-90-150 R300 FRP

FOE = Product family

70 = Rail height

FE = Flat Elbow

90 = Angle

150 = Width

R300 = Radius

FRP = Material

Table of Contents



Introduction to FRP products
6

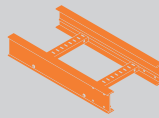

FOE Composite Cable Ladder System
36

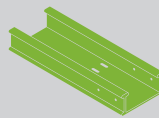

FTE Composite Cable Tray System
64



Nuts, Bolts and Fasteners
80



Company

About us

Oglaend System (ØS) is a global and market leading solution provider of multi-discipline support systems, cable ladders, cable trays and associated services. Whether it is oil & gas, shipbuilding, wind energy or renewables, our 40 years of experience in the offshore industry helps provide our customers with the most cost efficient and durable supports solutions across disciplines.

Our systems help reduce the total installed cost of supports by reducing total weight, installation time and engineering hours through standardization, simplification and digitalization. ØS support systems and innovative modular Mekano® triangular channels are pre-engineered using a finite element simulation environment called P4D® (Precision for Decision). Complemented with digital twins in all the major 3D software - PDMS, E3D, S3D our system seamlessly integrates with customer workflow.

Oglaend System is part of the Hilti Group, who are renowned for quality tools and fasteners and has a strong global presence in the construction, energy and industry segments. By combining Hilti's fastening on steel and Oglaend System's multidiscipline support systems we can provide the ultimate combination of flexibility, strength and corrosion resistance.



Factory Certification

We offer an extensive local stock and the best possible supply chain in the market. Our factories are located in Norway, Malaysia, and China. All factories are ISO 9001 certified and Norway, Malaysia and China also hold 14001 and 45001 certifications.



How do our products and system make you more competitive?

We always aim to make our customers more competitive by reducing the total installed cost. Our MultiGrid® installation concept reduces the total system cost of a project by up to 30%. By reducing weight, installation and engineering time, optimizing coordination between disciplines and simplifying future modification work. We reduce the amount of hot work required for an installation, which in turn also works to reduce the safety risks. The project risks are also reduced when engineering and construction are decoupled.

We partner with our customers throughout the entire project cycle. Our innovative and standardized support system is complemented with digital and engineering services, thereby increasing productivity and reducing the overall cost. ØS engineers supports clients in 3D design, structural analysis and product development.

Our systems can be delivered in pre-cut lengths as kits or prefabricated modules – thereby improving logistics and increasing construction speed. To further ensure safe and timely installation we provide construction team training and engineering support on the site. All to ensure lowest total system costs!

Advantages of FRP

Oglaend System's FRP cable management system has been designed to work in most extreme environments. Products are designed and manufactured to the highest quality standards while at the same time offering exceptional values to our customers. FRP products have many advantages, some of which are shown below.



CORROSION RESISTANCE

Resistant to a range of chemicals including salt water.



STRONG

Pultruded profiles have high loading capacity.



LOW MAINTENANCE

Resists corrosion, which eliminates the need for continual maintenance and cleaning. Provides a cost effective long term solution.



CONDUCTIVITY

Low thermal and electrical conductivity properties and high dielectric strength. Options for increased electrical conductivity are also available.



WEATHER RESISTANT

FRP is highly resistant to cold temperatures and performs exceptionally well in even the harshest climates.



LIGHT WEIGHT

High strength to weight ratio compared to traditional metallic support systems.



EMI AND RFI TRANSPARENCY

Non-conductive resins are transparent to electromagnetic and radio signal interference.



QUICK AND EASY INSTALLATION

Installation is simple and some items can be fabricated or modified on site, reducing the complications caused by late project changes. Installation and modifications are carried out with standard tools.

Flexibility of FRP

Oglaend System has an extensive standard FRP product range, much of which is stocked in strategic global locations. However, we also appreciate that many project require tailor made solutions to overcome unique challenges. In order to deliver standardization with flexibility, our FRP product range and manufacturing systems are designed to offer flexibility. Some examples are shown below:

- FRP profiles (including straight sections of Cable Tray and Cable Ladder) can be supplied in custom lengths.
- Cable Trays and Cable Ladder fittings can be provided in a wide variety of special angles and radius.
- Cable Ladder can be produced in custom widths between 150 and 900 mm.
- Cable Ladders can be produced with a variety of rung spacing.
- Cable Ladder Rungs can easily be added or removed.
- Risers can be easily adjusted so that an inside Riser can be used as an outside Riser and vice versa.
- Straight Cable Ladder sections can be supplied in kit form to save on shipping volume.
- The majority of accessories can be supplied in SS or FRP material.
- Fasteners can be supplied in SS or Composite material.
- We have standardized our products so that even after delivery it is possible for fastener and accessory material type to be changed without the need for any additional modifications. (This is applicable to the majority of our products).
- FRP products are easy to cut and drill on site and by using our Smart Jigs you can ensure that perforations for splice connectors are drilled in the correct location.



Complete FRP Product Line

As a complete system provider of cable management and multidiscipline support systems in many material types, with world wide references, our recommendations are trustworthy and focused. You can be confident that when you are next in the market for a non-metallic support system, Oglaend System FRP ladder, tray and support will be your best choice for value, ease of installation and technical quality.

FRP Product Line Advantages

- Smart Jigs for quick and easy installation.
- Save drilling time with our pre-slotted trays and ladder rungs!
- Trefoil SmartCleave® fits all cable ladders.
- ETIN™ Tubing Clamps fits all trays and ladders.
- Snap on covers for cable trays.
- Patented SmartLok rung insert for cable ladders.
- Bolt sets available in both FRP and flange nuts in stainless steel.
- Fitting accessories in FRP or SS material.
- Flexible installation around any obstacle with our Nonie™ principle for hinges, connectors and risers.

Cable ladder rung profile

Our patented channel with trim-edge design, helps to reduce the risk of cables being snagged or cut, and prevents the rung from moving vertically during assembly.

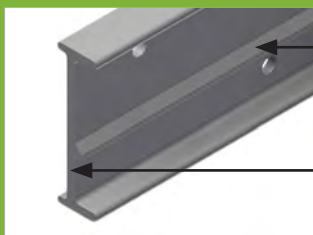

Trim Edge: Used to prevent cable snagging. Restricts movement of ladder rung vertically and adds rigidity.

I-beam: Unique I-beam design for better loading capacity and cross section stability.

FRP System Features



Nonie™ principle: adjustment possibilities in 4° steps.



Support channels, Cantilever arms and Ceiling T-supports available in FRP.



Our complete FRP support system is complemented by our MultiGrid® installation concept.

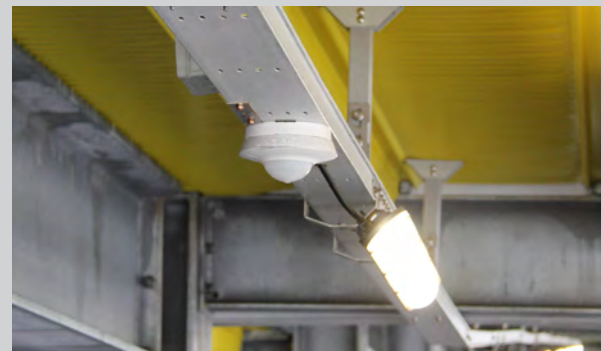

Comprehensive range of brackets for equipment.



Snap-lock feature on FTE tray covers up to 300 mm wide. High wind cover clamps are also available.



A complete range of fittings gives flexible installation around objects.



Pre-slotted design saves drilling time. Fix cables quick and easy with cable ties.



Smart Jigs are available for quick and easy installation.

FRP Composite Materials



Composite materials (FRP)

Oglaend System offers a range of resins to match the needs of our customers. From our standard polyester resin to our high performance options, we can meet your chemical, fire, smoke and toxicity requirements. Please contact our technical team with your individual project requirements for tailor made solutions.

GRP/FRP: Note, the pultruded process of manufacture means there is no difference in GRP/FRP material types.

Standard Product Construction (FRP)

Standard FRP Cable ladders are fabricated by joining pultruded cable ladder side profile to pultruded rungs that are punched. The rung is fixed to the side profile by using an SS fastener and Smartlok. Our standard Smartlok is manufactured using PA6 (nylon) material. Standard FRP Cable Ladder and FRP Cable Tray fittings are fabricated using SS angle plates and SS bolt sets unless stated otherwise.

In case our standard construction does not meet your project requirements please contact us for assistance. We have additional options of 'Smartlok' and the majority of our standard products can be supplied with FRP bolts and FRP angle plates upon request.

FRP Resin Guide

Polyester

Resin code: Standard article number

Polyester is the most widely used resin system. It offers good weathering properties with resistance to ultraviolet light and has good corrosion resistance. Our Polyester resin has been specially formulated to meet certain fire and smoke standards and is classified as a "class 1" resin in accordance with BS476 P7 and ASTM E84. Our standard polyester resin product range is UL approved.

Polyester with anti-static properties

Resin code: 'C1A'

Polyester resin can be given anti-static properties to meet project requirements. Anti-static resins contain carbon powder, which increases the conductivity of the material and as a result this material requires grounding.

Example article number:

Product: Cable Ladder FOE150 CL-300-3 FRP

Art. no.: 74438

- 74438 = Standard Class 1 Polyester resin
- 74438C1A = Class 1 polyester anti-static resin

Typical material certificates for given products can be supplied on request, however these requirements must be made known to us prior to ordering.

RESIN SELECTION CHART

- █ Polyester Resin
- █ Polyester Anti-Static Resin

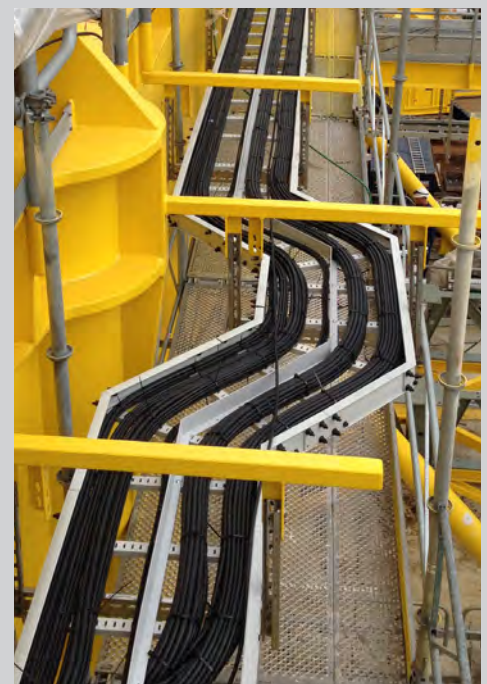
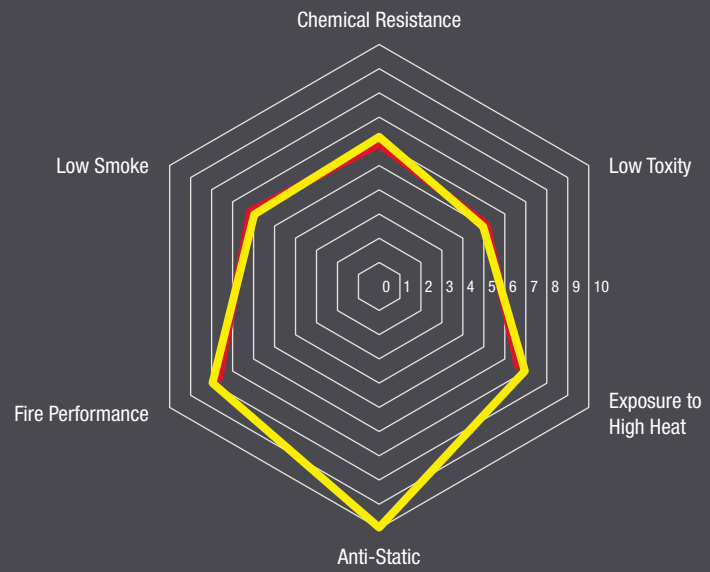

FRP Standards & Certificates

Oglaend System has carried out extensive testing together with fully accredited third part laboratories and institutes on our FRP product range. The following information represents some of this testing. If you require a particular standard that has not been indicated here, please contact us for more support.



-BS 476 PART 7 CLASS 1

This is a vertical flame spread test. Sample material is exposed to a high intensity flame for a predetermined amount of time. The heat source is then removed and the test begins, after 10 minutes the flame spread and rate is measured. All of our resin systems achieve the **highest** level possible.



ASTM E84

Tests the rate of flame spread and smoke emissions of materials. To test this, sample material is placed in a test box with a gas burner at one end and a smoke measurement device at the exhaust end. Air circulation is provided to assist the spread of the flame. Our FRP material received the **highest** level of certification in this test.



ASTM D257

This test measures the volume and surface resistivity of a material. Our material can be formulated to obtain a reading of 10^5 to 10^9 Ohm. We may lower the resistance and increase the anti-static properties by adding carbon. Careful consideration must be given to this process as a conductive product will require grounding.



ASTM D635

Standard test method for measuring the rate of burning and duration of burning in plastic products. Our FRP product achieved UL94 HB classification requirements.



ASTM D792G

Standard test for measurement of density. All of our resins are extremely lightweight, with densities ranging from 1699 kg/m^3 to 1965 kg/m^3 . This offers massive advantages over steel products which have a density approaching 8000 kg/m^3 . This reduces the cost of shipping and makes installations easier.



ASTM G154 2000A

Standard weathering test for non-metallic materials. It exposes the material to a high intensity ultraviolet light source. Thanks to our resin rich surface our material is highly resistant to ultraviolet light and is perfect for outdoor applications.



ASTM B-117

Tests a materials ability to resist the corrosive effect of salt water. All of our resins displayed zero deformation; FRP does not corrode or rust, making it the perfect material for use in areas exposed to sea spray.



IEC 60068-2-75

Is an impact test using an impact striking device. The material displayed no measurable damage up to an impact of 10 Joules.



IEC 60754-1



This test ensured that the material has zero halogen content. Halogens are a toxic group of elements on the periodic table that are sometimes used as flame retardants. All of our products are **halogen free**.



GOST 15150-69

The temperature extremes in Russia demand high requirements for performance, in particular for low temperature operation. Oglænd FRP retains its material properties well in extreme cold and the test concluded our material performs well in temperatures as low as -60°C.

CERTIFICATES & DECLERATIONS

Product type		Certificates		Declarations
				
		UL	CUL	CE
Cable Ladders	FOE70	Standard resin	Standard resin	Standard resin
	FOE100	Standard resin	Standard resin	Standard resin
	FOE150 GA	Standard resin	Standard resin	Standard resin
	FOE150 HD	Standard resin	Standard resin	Standard resin
Cable Trays	FTE50	Standard resin (up to 400mm wide)	Standard resin (up to 400mm wide)	Standard resin
	FTE80	Standard resin (up to 400mm wide)	Standard resin (up to 400mm wide)	Standard resin

Standard Resin = Class 1 Polyester.

FRP Manufacturing Process

When we designed Oglaend System FRP cable management and multi-discipline support system we had one thing in mind: To be Simply the Best! With over 40 years of experience as a global leader in the supply cable support systems, we were able to fully evaluate product requirements, market trends, customer requirements, environmental considerations, smart designs and cost factors.

With all these factors in mind, we have created a full range of products that are user friendly, cost efficient and deliver safe, high strength solutions. Combined with creative, user friendly fittings and smart accessories, we are confident we have achieved our goal to be Simply the Best!

Pultrusion process

Pultrusion is a continuous process of roving or mat/ roving bundles, which are drawn through a resin impregnated bath to coat each fiber with a specially formulated resin mixture. The impregnated fibers are then drawn through a heated die which forms the desired cross section. Curing of the thermosetting resin is initiated by heat in the die and catalyst in the resin. The rate of reaction is controlled by heating the die. The resulting high strength profile is cut to length and ready to be used in the Oglaend System FRP cable management and multi-discipline support system.



Standard Cable Ladder and Cable Tray fittings are fabricated using SS angle plates and SS bolt sets unless stated otherwise.

PHYSICAL PROPERTIES

Straight ladder section shall be pultruded glass reinforced with a premium resin system:

- a Our Ladder and tray members are designed specifically to optimize the load capacity in form of a beam section. This UNIQUE style has two important advantages, the first being the way our splice plates fits flush and tightly between the flanges thus preventing the plate from slipping at time of installation. The other is our patented rung to ladder attachment where the rung fits neatly between two flanges and locked using our patented insert.
- b Rung to side rail members connections shall be connected by fire retardant composite locking clip. The rung side rail mechanical connection shall resist both vertical shear and rung pullout.
- c The height of the rung is 24 mm to maximize cable installations.
- d All rungs have perforations along the length to aid easy installation of cables.
- e All sections can use Oglaend System ETIN™ tubing clamp and single or trefoil SmartCleats® and other fixing accessories.
- f Straight sections of ladder and tray are pre-drilled to accept connector plates.
- g All cut ends and drilled splice plate holes are sealed prior to goods leaving our manufacturing facilities.

FRP Typical Coupon Properties

Typical coupon properties of Oglænd System Reinforced Plastics structural fiberglass channels (Standard and Polyester fire retardant shapes). Properties derived according to ASTM test methods. Surface veil and ultraviolet inhibitors are standard in all channels.

Mechanical Properties	ASTM	Units	PE
Tensile Stress, LW	D-638	psi	30 000
Tensile Stress, CW	D-638	psi	7000
Tensile Modulus, LW	D-638	10 ⁶ psi	2.5
Tensile Modulus, CW	D-638	10 ⁶ psi	0.8
Compressive Stress, LW	D-695	psi	30 000
Compressive Stress, CW	D-695	psi	15 000
Compressive Modulus, LW	D-695	10 ⁶ psi	2.5
Compressive Modulus, CW	D-695	10 ⁶ psi	1.2
Flexural Stress, LW	D-790	psi	30 000
Flexural Stress, CW	D-790	psi	10 000
Flexural Modulus, LW	D-790	10 ⁶ psi	1.8
Flexural Modulus, CW	D-790	10 ⁶ psi	0.8
Modulus of Elasticity, E	Full Section	10 ⁶ psi	2.6
Shear Modulus	-	10 ⁶ psi	0.45
Short Beam Shear	D-2344	psi	4500
Punch Shear	D-737	psi	10 000
Notched Izod Impact, LW	D-256	ft-ls/in	25
Notched Izod Impact, CW	D-256	-	-

Physical Properties	ASTM	Units	PE
Barcol Hardness	D-2583	-	47
24 hour water absorption	D-570	% max	0.43
Density	D-792	bs./in. ³	.061-.070
Coefficient of Thermal Expansion, LW	D-696	10 ⁻⁶ in/°C	10

Physical Properties	ASTM	Units	PE
Arc Resistance, LW	D-495	seconds	120
Dielectric Strength, LW	D-149	kv./in.	35
Dielectric Strength, PF	D-149	volts/mil.	200
Dielectric Constant, PF	D-150	60hz	8



Complete FRP installation at Bremnes Seashore Hatchery in Trøvig, Norway.

Effect on strength with temperature

The strength properties of reinforced plastics are reduced when the material is continually exposed to high temperatures. Loading shall be reduced based on the below table. Percentages shown are approximates.

Temperature	Polyester Resin % of Strength
75°F (24°C)	100 %
100°F (38°C)	90 %
125°F (52°C)	78 %
150°F (66°C)	68 %
175°F (79°C)	60 %
200°F (93°C)	52 %

The test values in this chart are obtained from laboratory testing.

When high temperatures are present please consult the manufacturer for application advice. Freezing temperatures do not effect the load rating of cable ladders and the cable management system as the FRP material does not become fragile. Special consideration is required when service temperatures are over 200° Fahrenheit / 94° Celsius.

Please contact us for expert consultation for special requirements.

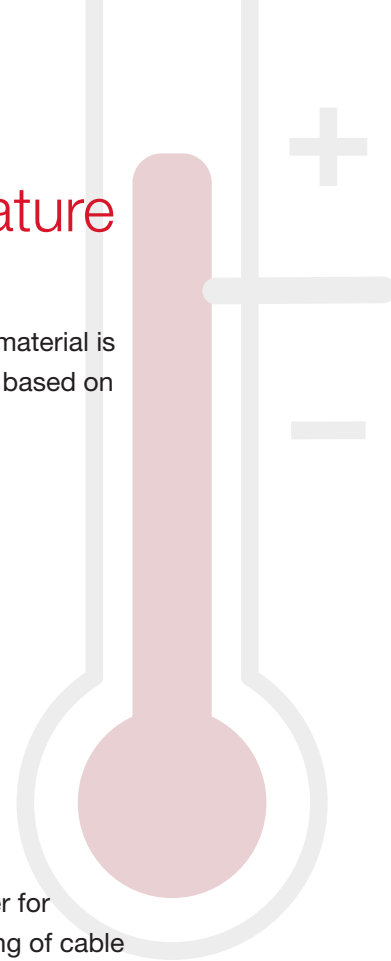

Thermal Contraction and Expansion

The table to the below compares the thermal contraction and expansion based on various temperature differentials for fiberglass, steel and aluminium cable trays. The values shown represent the length of cable tray that will produce a 16 mm (5/8") movement between expansion connectors for the indicated temperature differential. Fiberglass has the least movement and requires least expansion joints. This simplifies the design and installation and minimizes expansion dynamic forces on the structure.

Temperature Differential	FRP Ft. (m)	Steel Ft. (m)	Aluminium Ft. (m)
25°F (14°C)	417 (126)	320 (97)	162 (49)
50°F (28°C)	208 (63)	160 (48)	81 (25)
75°F (42°C)	138 (42)	106 (48)	54 (16)
100°F (56°C)	104 (32)	80 (24)	40 (12)
125°F (69°C)	83 (25)	63 (19)	32 (10)
150°F (83°C)	69 (21)	53 (16)	26 (8)
175°F (97°C)	59 (17)	45 (13)	23 (6)

Chemical Exposure Chart

The data that is contained in this chart is based on information obtained from raw material suppliers. Temperatures used are neither minimum nor maximum, but represent a cross section of test conditions. The information stated is done so without guarantee, we advise that you evaluate this information and suggest you test the material in your own laboratory or conduct actual field tests before use.

Chemical Environment	ISO Polyester		Chemical Environment	ISO Polyester	
	% Concentrate	Temp °F		% Concentrate	Temp °F
Acetic Acid	10	190	Lactic Acid	SAT	170
Acetic Acid	50	125	Lead Acetate	SAT	170
Aluminum Chlorine	SAT	170	Lead Chloride	SAT	140
Aluminum Hydroxide	SAT	160	Lead Nitrate	SAT	▲
Aluminum Nitrate	SAT	150	Linseed Oil	100	150
Aluminum Sulfate	SAT	180	Lithium Chloride	SAT	150
Ammonium Chloride	SAT	170	Magnesium Carbonate	SAT	140
Ammonium Hydroxide	1	100	Magnesium Chloride	SAT	170
Ammonium Hydroxide	28	■	Magnesium Hydroxide	SAT	150
Ammonium Carbonate	■	■	Magnesium Nitrate	SAT	140
Ammonium Bicarbonate	15	125	Magnesium Sulfate	SAT	170
Ammonium Nitrate	SAT	160	Mercuric Chloride	SAT	150
Ammonium Persulfate	SAT	■	Mercurous Chloride	SAT	140
Ammonium Sulfate	SAT	170	Mineral Oils	100	170
Amyl Alcohol	ALL	■	Naptha	100	140
Amyl Alcohol Vapor	■	140	Nickel Chloride	SAT	170
Benzene Sulfonic Acid	25	110	Nickel Nitrate	SAT	170
Benzonic Acid	SAT	150	Nickel Sulfate	SAT	170
Benzoly Alcohol	100	■	Nitric Acid	5	140
Borax	SAT	170	Nitric Acid	20	70
Calcium Carbonate	SAT	170	Oleic Acid	100	170
Calcium Chloride	SAT	170	Oxalic Acid	ALL	75
Calcium Hydroxide	25	70	Paper Mill Liquors	■	100
Calcium Nitrate	SAT	180	Perchlorethylene	100	■
Calcium Sulfate	SAT	180	Perchloric Acid	■	■
Carbon Disulfide	■	■	Perchloric Acid	■	■
Carbonic Acid	SAT	130	Phosphoric Acid	10	160
Carbon Dioxide Gas	▲	200	Phosphoric Acid	100	120
Carbon Monoxide Gas	▲	200	Potassium Aluminium Sulfate	SAT	170
Carbon Tetrachloride	■	■	Potassium Bicarbonate	50	80
Chlorine, Dry Gas	▲	140	Potassium Carbonate	10	■
Chlorine, Wet Gas	▲	■	Potassium Chloride	SAT	170
Chlorine Water	SAT	■	Potassium Chromate	SAT	170
Chromic Acid	5	70	Potassium Hydroxide	■	■
Citric Acid	SAT	170	Potassium Nitrate	SAT	170
Copper Chloride	SAT	170	Potassium Permangante	SAT	75
Copper Cyanide	SAT	170	Potassium Sulfate	SAT	170
Copper Nitrate	SAT	170	Propylene Glycol	ALL	170
Crude Oil, Sour	100	170	Phthalic Acid	▲	▲
Cyclohexane, Vapor	ALL	100	Sodium Acetate	SAT	160
Diesel Fuel	100	160	Sodium Benzoate	SAT	170
Diethyl Ether	■	■	Sodium Bicarbonate	SAT	160
Dimethyl Phthalate	■	■	Sodium Bisulfate	ALL	170
Ethanol	50	75	Sodium Bromide	ALL	170
Ethyl Acetate	■	■	Sodium Carbonate	10	80
Ethylene Chloride	■	■	Sodium Chloride	SAT	170
Ethylene Glycol	100	90	Sodium Cyanide	SAT	170
Fatty Acids	SAT	180	Sodium Hydroxide	■	■
Ferric Chloride	SAT	170	Sodium Hydroxide	■	■
Ferric Nitrate	SAT	170	Sodium Hypochlorite	■	■
Ferric Sulfate	SAT	170	Sodium Monophosphate	SAT	170
Ferrous Chloride	SAT	170	Sodium Nitrate	SAT	170
Fluoboric Acid	■	■	Sodium Sulfate	SAT	170
Fluosilicic Acid	■	■	Sodium Thiosulfate	ALL	100
Formaldehyde	50	75	Stannic Chloride	SAT	160
Formic Acid	■	■	Sulfated Detergent	0/50	170
Gasoline	100	80	Sulfur Dioxide	100	80
Glucose	100	170	Sulfur Trioxide	100	80
Glycerine	100	150	Sulfuric Acid	93	■
Heptane	100	110	Sulfuric Acid	50	■
Hexane	100	90	Sulfuric Acid	25	75
Hydrobromic Acid	50	120	Sulfurous Acid	■	80
Hydrobromic Acid	10	150	Tartaric Acid	■	170
Hydrobromic Acid	20	140	Tetrachloroethylene	■	■
Hydrobromic Acid	37	75	Toluene	■	■
Hydrobromic Acid	■	■	Trisodium Phosphate	■	■
Hydrogen Bromide, Dry	100	190	Urea	SAT	130
Hydrogen Bromide, Wet	100	75	Vinegar	100	170
Hydrogen Chloride	▲	120	Water, Distilled	100	170
Hydrogen Peroxide	30	■	Water, Tap	100	170
Hydrogen Sulfide, Dry	■	140	Water, Salt	SAT	170
Hydrogen Sulfide, Wet	V	140	Zinc Chloride	SAT	170
Hypochlorous Acid	10	70	Zinc Nitrate	SAT	170
Isopropyl Alcohol	■	■	Zinc Sulfate	SAT	170
Kerosene	100	140			

LEGEND:
 SAT - Saturated
 ▲ Not available
 ■ Not recommended
 V - Vaporous

FRP Installation Guidelines

RECOMMENDED PROTECTIVE GEAR

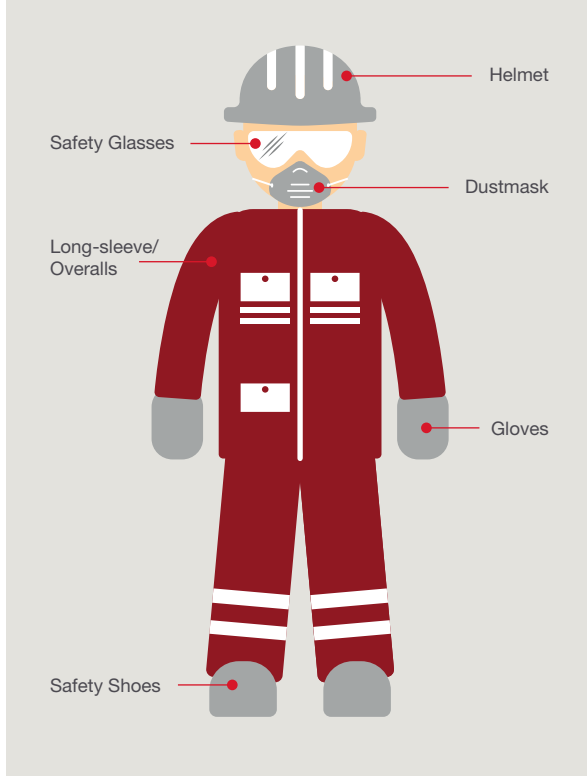

FRP products are inherently stable and safe to handle. The dust created when cutting FRP can however cause skin and respiratory irritation. This is avoided using standard personal protective equipment as shown.

All installations must adhere to local, national, international and branch health, safety and environmental regulations. Unless appropriate safety measures are taken, cutting and grinding operations can be hazardous activities, with significant risk of personal injury or installation damage. Any installation should be carried out by competent persons according to planned work schedules and appropriate safety measures must be taken to avoid hazardous situations. Always wear protective gear when cutting or grinding fiberglass. Even though the dust created is non-toxic, it can still cause skin irritations and itching.



WARNING!

Fiberglass products should not be used as a walkway, ladder or any type of support for personnel. Our cable ladders and trays are designed to be used as mechanical support for cables and tubing only.

SELECTING THE RIGHT TOOLS

- On-site cutting is easily done with the use of a circular power saw.
- Diamond or carbide grit edged saw blades and carbide tip drill bits are best suited for fiberglass.
- Fiberglass is easy to work with and only requires regular hand-tools for installation.

CUTTING AND DRILLING

- When cutting, grinding or sanding fiberglass it is important to wear appropriate clothing to protect the operator. Safety glasses, dust mask and gloves are necessary.
- We also recommend wearing a long-sleeved shirt or overalls when working with fiberglass. Because the non-toxic dust that is created can cause skin irritations. The amount of irritant varies among different individuals, and is easily reduced or eliminated by wearing protective clothing.
- Avoid excessive pressure when sawing or drilling, because this force can wear down the tools.
- Refrain from generating excessive heat in any sawing or drilling operation. The heat can soften the resin and produce a rough edge. Excessive heat will also burn the resin and fiberglass.
- Provide rigid support for the profile material during the cutting or drilling process. Movement may cause chipping at the profile edges.

- Use the offered Oglaend System drilling jigs in order to perform proper productive and precise perforations. Do not use a profile member that has been perforated or damaged in wrong positions that may reduce its structural strength.

AFTER TREATMENT AND INSTALLATION

- From our extensive testing and on-site experience, the quality of our FRP profiles are such that cut ends and holes do not require sealant in most harsh environments. The requirement for additional sealant applied to cut ends and holes should be considered by the specifier, engineering company or owner based on their environmental evaluation, and specified as a scope of work for the installation contractor.
- When installing cable ladders or cable trays from Oglaend System, ensure that you only use original parts, which make up part or all of the main support system. This includes for example splice plates, fittings, fixing clamps and FRP supports. Using non Oglaend System products will affect the loading performance and warranty of the whole system.

To prolong the service life of the product it should be installed in compliance with the standards set forth in the current version of National Electric Code and NEMA Publications FG-1.

INSTALLING CABLE LADDERS AND CABLE TRAYS CORRECTLY

In order to minimize deflection and maximize the safe working load, the cable ladders or cable trays should be installed so that splice joints between horizontal runs sit at the quarter point of the span as illustrated below.

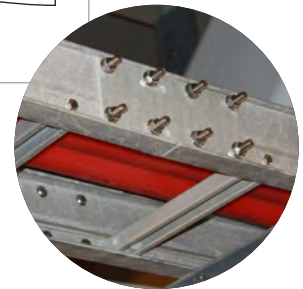
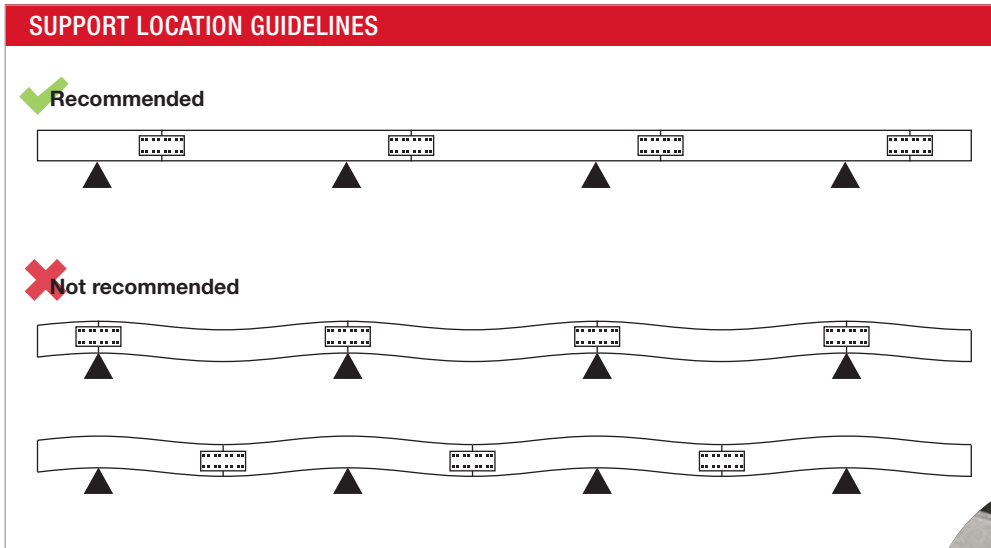

MECHANICAL LOADING SPECIFICATIONS

NEMA FG-1

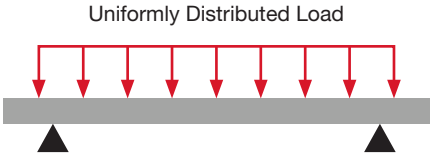

Uniformly Distributed Load

All our FRP cable ladders have been tested under the NEMA FG-1 mechanical loading specification. This is a certificate based testing standard. Grading occurs on a combined alphabetic (A-C) and numeric (8, 12, 16, 20) scales. The alphabetic grading denotes the max loading (UDL) and the numeric grading denotes the span distance in feet between supports.

The loading test and grading included in NEMA FG-1 standard does not apply to cable tray.

See page 34 for Cable Ladder SWL recommendations.

IEC 61537

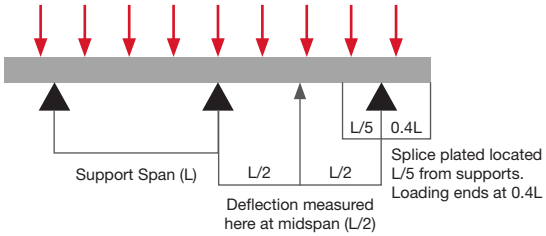

Support Span (L)

Deflection measured here at midspan (L/2)

Splice plated located L/5 from supports. Loading ends at 0.4L

This is an international testing standard for cable trays and cable ladders. The safe working load obtained using these methods include with a safety factor of 1.7. The products were tested under a worst case scenario methodology i.e. maximum width and spans.

FRP Reference List

CLIENT	PROJECT	LOCATION	PRODUCT DELIVERED
Total	Clov FPSO	Angola	FOE70, FTE50
Alfasi	Desalination Plant	Australia	FOE70
Downer EDI	SSJV Desalination Plant	Australia	FOE100 Ladder, Fittings HD Supports
Leonard Electrics	State Aquatic Centre	Australia	FOE70
Southern Cross Electrical c	Pigment plant upgrade	Australia	FOE100 Ladder
Vestas Wind Mill	Various Windmill Park	Australia	Support Channels
BP	Accomodation	Azerbaijan	FOE100 Ladder, Fittings
BelWind	Transformer Platform	Belgium	FOE Ladder, FTE Tray, FRP Support
London Array	Transformer Platform	Belgium	FOE, FTE, FTE Antistatic, FRP Support
ConocoPhillips	RUP Bohai Bay	China	FOE150 Ladders and Fittings
ConocoPhillips	Well Head, D, E, F Bohai Bay	China	FOE150 Ladders
Copenhagen Zoo	Artic Ring	Denmark	FOE70
ETS Track	Boulevard Tunnel	Denmark	FOE70 Ladders
Semco Maritime	Horns Rev 2 Accomodation	Denmark	FOE Ladders and FTE Trays
Vestas Wind Mill	Various Windmill park	Denmark & Germany	Support Channels
British Gas	India Tapti project	India	FOE150 Ladders (Nema 20C)
Aqua Treat	Oil & Gas	Jordan	FTE Trays
JV Inkai	Petrochemical plate	Kazakhstan	FOE150 Ladders and Fittings
Lynas	Lamps up	Malaysia	FOE Ladders (Nema 20C)
Sime Darby	Maersk	Malaysia	FOE Ladders (Nema 16B) and FTE Trays, Fittings (Nema 20C)
Sime Darby	Kumag Cluster	Malaysia	FOE150 Ladders, Fittings and FTE Trays
SOME	Zatwika Project	Myanmar	FOE150, FTE50
DONG Energy	Transformer Platform	Netherland	FOE Ladders
Avinor	Sola Airport	Norway	FOE70, FTE50, Support Channels
Hemworthy	Pazfloor FPSO	Norway	FTE Tray
Siemens	Norsk Hydro	Norway	FOE Ladders, FTE Trays and FRP Support
Helgevold Elektro	Bremnes Seashore	Norway	FOE Ladders, FTE Trays and FRP Support
Oman Methanol	Expansion	Oman	FTE Tray
Cegelec	New Doha Airport	Qatar	FOE100 Ladders, FTE50
SPIE Industrial	Kingsway Tunnel Merseyside	United Kingdom	Olstar
National Grid – Kier/Siemens	Upgrade of Network Plants	United Kingdom	Polyester C1
Network Rail	Upgrade of Sub Stations	United Kingdom	Polyester C1
Highways Agency	M6 Smart Motorway Bridges	United Kingdom	Polyester C1



*Bremnes Seashore
Hatchery, Norway.*



FOE COMPOSITE CABLE LADDER SYSTEM

Oglaend System corrosion resistant glass fibre reinforced plastic (FRP/GRP) cable ladders are designed to deliver weight reductions while maintaining strength and maximizing loading capability. The design delivers HSE improvements when lifting and fitting ladder and support equipment. Cable ladders are available in different resin materials, each formulated to satisfy special project requirements.

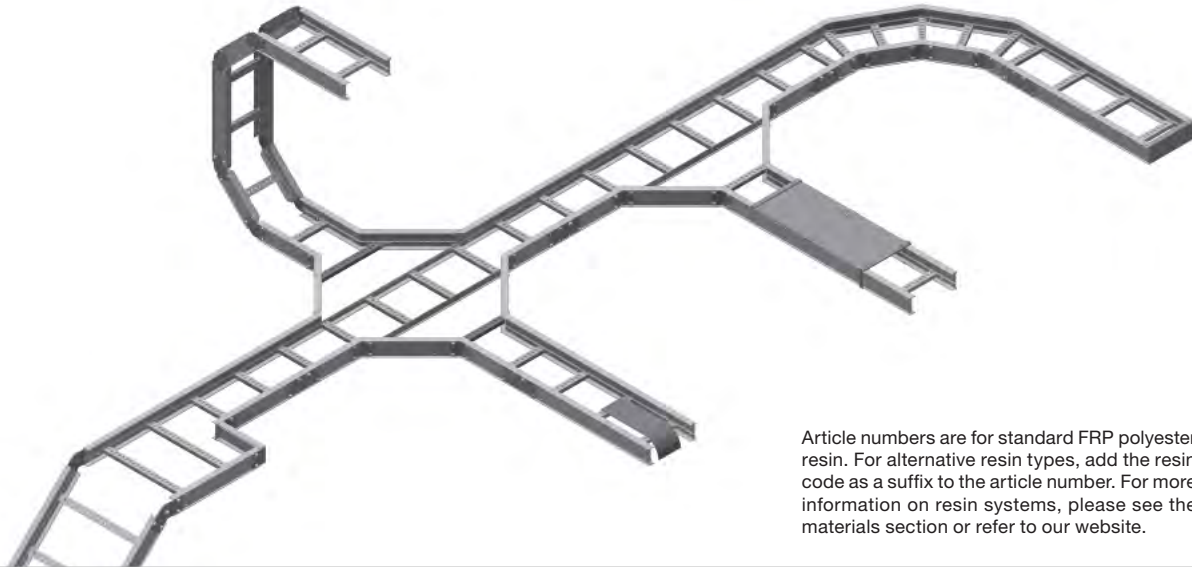

Article numbers are for standard FRP polyester resin. For alternative resin types, add the resin code as a suffix to the article number. For more information on resin systems, please see the materials section or refer to our website.



MATERIALS



3D LIBRARIES

AVEVA (E3D / PDMS)
Hexagon (Intergraph Smart 3D)
Bentley

CERTIFICATES & DECLARATIONS

Type	 UL/CUL	 CE
FOE70	Standard resin	Standard resin
FOE100	Standard resin	Standard resin
FOE150 GA	Standard resin	Standard resin
FOE150 HD	Standard resin	Standard resin

CABLE TRAYS

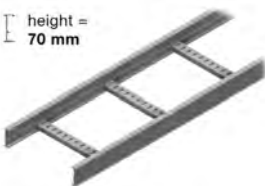

FOE70
Siderail height 70 mm

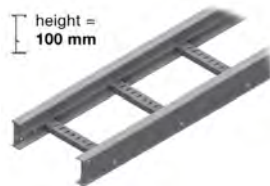

FOE100
Siderail height 100 mm

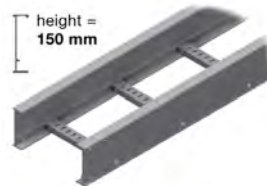

FOE150 GA
GA = General Application



FOE150 HD
HD = Heavy Duty

FOE200 also available on request.

LOAD DATA

Cable Ladder	Rail Height (mm)	Loading Depth (mm)	SWL 2 m (kg/m)	SWL 3 m (kg/m)	Available lengths (m)	Nema FG-1	Wall thickness FRP (mm)
FOE70	70	46	263	103	3	8A	4
FOE100	100	71	-	230	3/6	12C	4
FOE150 GA	150	121	-	402	3/6	16B	4 ¹ /7 ²
FOE150 HD	150	121	-	460	3/6	20C	7

SWL = Safe Working Load, ¹Upper Wall, ²Lower Wall
Loading data according to IEC61537. The length of the end span must be reduced to 3/4 of the support spacing and with no splices on the end span.

DIFFERENT HEIGHTS (MM):

Different ladder heights to give more choice for loading space availability. Designed with unique I-beam for superior loading capacity.

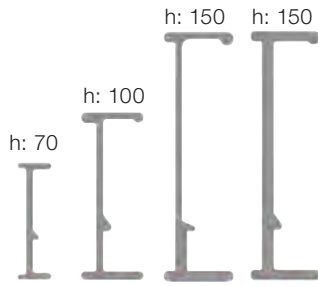

VARIABLE RUNG WIDTH (MM):

Standard widths range from 150-900 mm. Rung widths and rung spacing can be customized to project requirements on application.

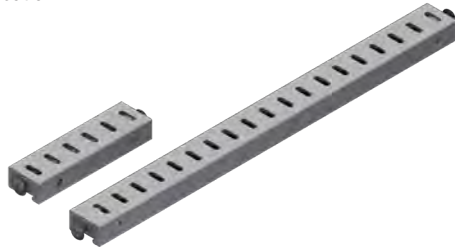

FITTING ACCESSORIES AVAILABLE IN FRP AND SS

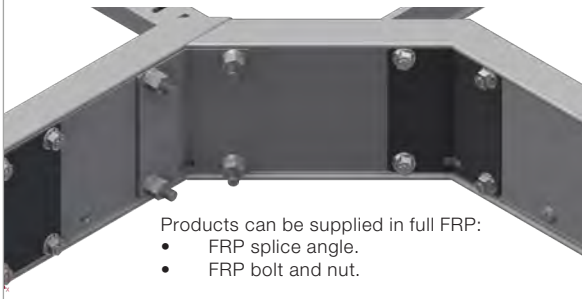

- Products can be supplied in full FRP:
- FRP splice angle.
 - FRP bolt and nut.

HEAVY DUTY COVER FIXING CLAMPS

Available in FRP and SS materials.

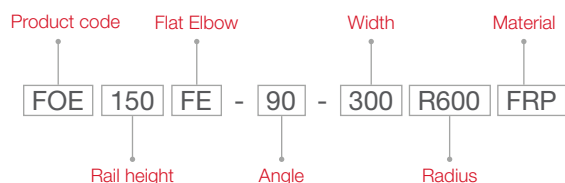
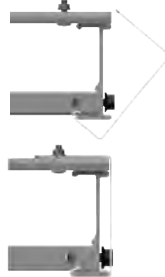

FE = Flat Elbow, TE = Tee-Piece, CP = Cross-Piece, CO = Cover

TABLE OF CONTENTS

FOE Smart Features 38

FOE70 Cable Ladder System

FOE70 Cable Ladder System 39

FOE70 Fittings 39

FOE70 Fixings..... 43

FOE100 Cable Ladder System

FOE100 Cable Ladder System 45

FOE100 Fittings 45

FOE100 Fixings..... 50

FOE150 Cable Ladder System

FOE150 GA Cable Ladder System 52

FOE150 HD Cable Ladder System 52

FOE150 Fittings..... 53

FOE150 Fixings 58

FOE Cover & Accessories

FOE Cover 60

FOE Cover Clamps 62

FOE Accessories 62



Intellectual Property Rights
Please note that many of the products presented in this catalogue are protected by our intellectual property rights in the form of patents, registered designs and trademarks, and that we have made the strategic decision to police and enforce these rights in all relevant jurisdictions.

FOE Smart Features

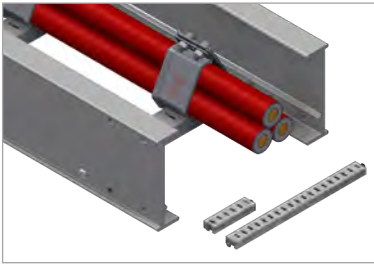

PERFORATED RUNG DESIGN

Standard widths range from 150-900 mm. This allows for our high voltage cable cleats SmartCheat® to be easily installed. ETIN™ tubing clamps can also be installed. Flexible rung attachment allows additional rungs to be installed.

C-profile advantages; increased loading complete with perforations, prohibits liquid entrapment, long maintenance service life, range of smart-loks available to meet different requirements, rung widths and rung spacing can be customized to project requirements on application.

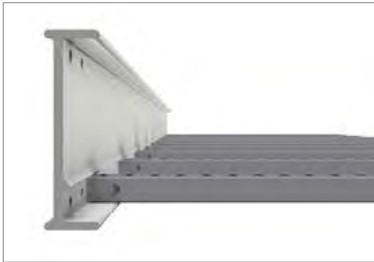

LADDER SIDERAIL

Ladder Siderail has unique off centre side profiles. Easy installation and secure fitting of splice plates. Increased load capacity at splice location. Roll edges for easy handling. Trim edge, reduces cable snagging, roll over and aids stability to reduce rung movement.



SPLICE CONNECTORS

Full height splice and joint connectors with A4 quality bolt sets which can handle the same loadings as the ladder system itself. The products are delivered with perforations for use with splice connectors predrilled.

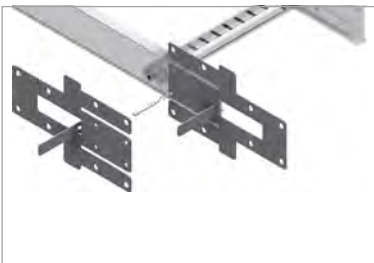

DRILL JIG

Smart Jig available for easy and accurate drilling.



FLEXIBLE RISER

Allows user to change between inside or outside riser (simply remove then invert the splice angle plate).



CABLE LADDER COVER

Covers are available for all widths of FOE Cable Ladders and fittings. For straight Cable Ladders, covers are supplied in 3 meter lengths consisting of 4 interlocking sections. These covers are designed this way to reduce possible sagging across the width of the cover.

The bolts used to interlock the sections are also used to install the HD Cover fixing clamp. Covers for fittings are supplied as a single flat cover.

FOE70 Cable Ladder System

FOE70 Straight Cable Ladder

Composite Cable Ladder with 70 mm rail height certified to class 8A according to Nema FG-1 standard. 3 m length.

Type Description	FRP	FRP (kg)
FOE-70 CL-150-3000	73700	5,7
FOE-70 CL-200-3000	70300	5,9
FOE-70 CL-300-3000	73701	6,3
FOE-70 CL-400-3000	70301	6,6
FOE-70 CL-450-3000	73702	6,8
FOE-70 CL-500-3000	70302	6,9
FOE-70 CL-600-3000	73703	7,3



FOE70 Fittings

90° Flat Elbows

Compact design Flat Elbow in radius 300 mm. (For more radius options please contact us.)

Type Description	FRP	FRP (kg)
FOE-70 FE-90-150 R300	73706	2,2
FOE-70 FE-90-200 R300	70303	2,3
FOE-70 FE-90-300 R300	73307	2,5
FOE-70 FE-90-400 R300	70304	3,2
FOE-70 FE-90-450 R300	73708	3,3
FOE-70 FE-90-500 R300	73707	3,5
FOE-70 FE-90-600 R300	73709	3,8



45° Flat Elbows

Compact design Flat Elbow in radius 300 mm. (For more radius options please contact us.)

Type Description	FRP	FRP (kg)
FOE-70 FE-45-150 R300	73712	1,4
FOE-70 FE-45-200 R300	70305	1,4
FOE-70 FE-45-300 R300	73713	1,6
FOE-70 FE-45-400 R300	70306	1,7
FOE-70 FE-45-450 R300	73714	2,0
FOE-70 FE-45-500 R300	70307	2,1
FOE-70 FE-45-600 R300	73715	2,3



Tee-Piece

Compact design Tee-Piece in radius 300 mm.
(For more radius options and for unequal fittings please contact us.)

Type Description	FRP	FRP (kg)
FOE-70 TE-150/150 R300	73718	3,2
FOE-70 TE-200/200 R300	70308	3,3
FOE-70 TE-300/300 R300	73719	3,6
FOE-70 TE-400/400 R300	70309	4,1
FOE-70 TE-450/450 R300	73720	4,3
FOE-70 TE-500/500 R300	70310	4,5
FOE-70 TE-600/600 R300	73721	4,8



Cross-Piece

Compact design Cross-Piece in radius 300 mm.
(For more radius options and for unequal fittings please contact us.)

Type Description	FRP	FRP (kg)
FOE-70 CP-150/150 R300	73724	4,3
FOE-70 CP-200/200 R300	70311	4,5
FOE-70 CP-300/300 R300	73725	4,9
FOE-70 CP-400/400 R300	70312	5,3
FOE-70 CP-450/450 R300	73726	5,4
FOE-70 CP-500/500 R300	70313	5,6
FOE-70 CP-600/600 R300	73727	5,9



Riser Part

Riser Link which can be combined with Angle Plates and additional Riser Links to create required configurations.

Type Description	FRP	FRP (kg)
FOE-70 RI-PA-150	73741	0,60
FOE-70 RI-PA-200	70403	0,60
FOE-70 RI-PA-300	73742	0,60
FOE-70 RI-PA-400	70404	0,70
FOE-70 RI-PA-450	73743	0,70
FOE-70 RI-PA-500	70405	0,70
FOE-70 RI-PA-600	73744	0,70



Inside Fixed Riser 90°. Radius 400 mm

Fixed angle Inside Riser piece. Compact design. Preassembled in composite system. Exact radius 409 mm.

Type Description	FRP	FRP (kg)
FOE-70 RI-IN-90-150 R400	73747	0,90
FOE-70 RI-IN-90-200 R400	70415	0,90
FOE-70 RI-IN-90-300 R400	73748	1,0
FOE-70 RI-IN-90-400 R400	70416	1,0
FOE-70 RI-IN-90-450 R400	73749	1,0
FOE-70 RI-IN-90-500 R400	70417	1,1
FOE-70 RI-IN-90-600 R400	73750	1,1

8 Locking Bolt set(s) M6x16 included.



Inside Fixed Riser 90°. Radius 600 mm

Fixed angle Inside Riser piece. Compact design. Preassembled in composite system. Exact radius 607 mm.

Type Description	FRP	FRP (kg)
FOE-70 RI-IN-90-150 R600	73753	1,6
FOE-70 RI-IN-90-200 R600	70418	1,7
FOE-70 RI-IN-90-300 R600	73754	1,8
FOE-70 RI-IN-90-400 R600	70419	1,8
FOE-70 RI-IN-90-450 R600	73755	1,9
FOE-70 RI-IN-90-500 R600	70420	1,9
FOE-70 RI-IN-90-600 R600	73756	2,0

8 Locking Bolt set(s) M6x16 included.



Inside Fixed Riser 90°. Radius 800 mm

Fixed angle Inside Riser piece. Compact design. Preassembled in composite system. Exact radius 804 mm.

Type Description	FRP	FRP (kg)
FOE-70 RI-IN-90-150 R800	73759	2,4
FOE-70 RI-IN-90-200 R800	70421	2,4
FOE-70 RI-IN-90-300 R800	73760	2,6
FOE-70 RI-IN-90-400 R800	70422	2,6
FOE-70 RI-IN-90-450 R800	73761	2,7
FOE-70 RI-IN-90-500 R800	70423	2,7
FOE-70 RI-IN-90-600 R800	73762	2,9

8 Locking Bolt set(s) M6x16 included.



Outside Fixed Riser 90°. Radius 400 mm

Fixed angle Outside Riser. Compact design. Preassembled in composite system. Exact radius 393 mm.

Type Description	FRP	FRP (kg)
FOE-70 RI-OU-90-150 R400	73765	0,90
FOE-70 RI-OU-90-200 R400	70424	0,90
FOE-70 RI-OU-90-300 R400	73766	1,0
FOE-70 RI-OU-90-400 R400	70425	1,0
FOE-70 RI-OU-90-450 R400	73767	1,0
FOE-70 RI-OU-90-500 R400	70426	1,1
FOE-70 RI-OU-90-600 R400	73768	1,1

8 Locking Bolt set(s) M6x16 included.



Outside Fixed Riser 90°. Radius 600 mm

Fixed angle Outside Riser. Compact design. Preassembled in composite system. Exact radius 591 mm.

Type Description	FRP	FRP (kg)
FOE-70 RI-OU-90-150 R600	73771	1,6
FOE-70 RI-OU-90-200 R600	70427	1,7
FOE-70 RI-OU-90-300 R600	73772	1,8
FOE-70 RI-OU-90-400 R600	70428	1,8
FOE-70 RI-OU-90-450 R600	73773	1,9
FOE-70 RI-OU-90-500 R600	70429	1,9
FOE-70 RI-OU-90-600 R600	73774	2,0

8 Locking Bolt set(s) M6x16 included.



Outside Fixed Riser 90°. Radius 800 mm

Fixed angle Outside Riser. Compact design. Preassembled in composite system. Exact radius 788 mm.

Type Description	FRP	FRP (kg)
FOE-70 RI-OU-90-150 R800	73777	2,4
FOE-70 RI-OU-90-200 R800	70430	2,4
FOE-70 RI-OU-90-300 R800	73778	2,6
FOE-70 RI-OU-90-400 R800	70431	2,6
FOE-70 RI-OU-90-450 R800	73779	2,7
FOE-70 RI-OU-90-500 R800	70432	2,7
FOE-70 RI-OU-90-600 R800	73780	2,9

8 Locking Bolt set(s) M6x16 included.



FOE70 Fixings

Splice plates are delivered in a set for one side of each ladder, complete with bolts as shown. Two sets are therefore required for a ladder connection.

All standard splice connectors in both SS and FRP material are supplied with SS fasteners.

Splice Connector

Splice Connector for connecting Cable Ladders and Fittings.

Type Description	Fasteners included	SS	SS (kg)	FRP
FOE-70 SC	4xM6	70397	0,20	70396



Splice Angle Horizontal

Horizontal 90° Splice for FOE Cable Ladders. Note that the SS type is supplied as a flat plate which may be bent to any angle.

Type Description	Fasteners included	SS	SS (kg)	FRP
FOE-70 SA-HO	4xM6	70399	0,30	70398



Hinge Vertical

Vertical Hinge for FOE Cable Ladders in two types. The heavy duty SS version can be locked in place in increments of 4°.

Type Description	Fasteners included	SS	SS (kg)	FRP
FOE-70 HV-HD	6xM6	74863	0,30	70402



Reducer Part

Part for increasing or reducing Cable Ladder width in set increments. Universal design which can be used for left or right side independently or both sides together. When fitting on just one side, one additional splice connector is required (ordered separately).

Type Description	FRP	FRP (kg)
FOE-70 RP-150	73730	0,30
FOE-70 RP-200	70326	0,40
FOE-70 RP-300	73731	0,50
FOE-70 RP-450	73732	0,60
FOE-70 RP-500	73733	0,60



2 Locking Bolt set(s) M6x16 included.

End Cover

End Cover to close the end of the Cable Ladder.
Provides a tidy finish.

Type Description	FRP	FRP (kg)
FOE-70 EC-150	73735	0,090
FOE-70 EC-200	70393	0,10
FOE-70 EC-300	73736	0,20
FOE-70 EC-400	70394	0,20
FOE-70 EC-450	73737	0,30
FOE-70 EC-500	70395	0,30
FOE-70 EC-600	73738	0,30

2 ST4.8x13 Self Tapping Screw(s) included.



Dividers

Divider for FOE-70 Cable Ladder. Supplied in 3 m lengths.
Dividers are used for separation and segregation of different systems.

Type Description	Fasteners included	FRP	FRP (kg)
FOE-70 DI	4xM6	73783	2,4



FOE100 Cable Ladder System

FOE100 Cable Ladder

Composite Cable Ladder with 100 mm rail height certified to class 12C according to Nema FG-1 standard.



FOE100 Cable Ladder in 3 m length

Type Description	FRP	FRP (kg)
FOE-100 CL-150-3000	74429	10,0
FOE-100 CL-300-3000	74430	11,1
FOE-100 CL-450-3000	74431	12,1
FOE-100 CL-600-3000	74432	13,3
FOE-100 CL-750-3000	74433	14,4
FOE-100 CL-900-3000	74434	15,2

FOE100 Cable Ladder in 6 m length

Type Description	FRP	FRP (kg)
FOE-100 CL-150-6000	74746	20,1
FOE-100 CL-300-6000	74747	22,3
FOE-100 CL-450-6000	74748	24,2
FOE-100 CL-600-6000	74749	26,7
FOE-100 CL-750-6000	74750	28,9
FOE-100 CL-900-6000	74751	30,5

FOE100 Fittings

90° Flat Elbows

Compact design Flat Elbow in composite system. (For more radius options please contact us.)



Radius 300 mm

Type Description	FRP	FRP (kg)
FOE-100 FE-90-150 R300	74606	-
FOE-100 FE-90-300 R300	74607	4,7
FOE-100 FE-90-450 R300	74608	6,2
FOE-100 FE-90-600 R300	74609	7,0
FOE-100 FE-90-750 R300	74610	8,0
FOE-100 FE-90-900 R300	74611	8,9

Radius 600 mm

Type Description	FRP	FRP (kg)
FOE-100 FE-90-150 R600	73106	5,8
FOE-100 FE-90-300 R600	73107	6,7
FOE-100 FE-90-450 R600	73108	7,5
FOE-100 FE-90-600 R600	73109	8,6
FOE-100 FE-90-750 R600	73110	10,0
FOE-100 FE-90-900 R600	73111	11,0

45° Flat Elbows

Compact design Flat Elbow in composite system.
(For more radius options please contact us.)



Radius 300 mm

Type Description	FRP	FRP (kg)
FOE-100 FE-45-150 R300	74624	2,5
FOE-100 FE-45-300 R300	74625	2,9
FOE-100 FE-45-450 R300	74626	3,7
FOE-100 FE-45-600 R300	74627	4,3
FOE-100 FE-45-750 R300	74628	4,8
FOE-100 FE-45-900 R300	74629	5,3

Radius 600 mm

Type Description	FRP	FRP (kg)
FOE-100 FE-45-150 R600	73124	3,4
FOE-100 FE-45-300 R600	73125	3,9
FOE-100 FE-45-450 R600	73126	4,3
FOE-100 FE-45-600 R600	73127	4,9
FOE-100 FE-45-900 R600	73129	5,9
FOE-100 FE-45-750 R600	73128	5,4

Tee-Piece

Compact design Tee-Piece Fitting in composite system. (For more radius options and for unequal fittings please contact us.)



Radius 300 mm

Type Description	FRP	FRP (kg)
FOE-100 TE-150/150 R300	74506	5,9
FOE-100 TE-300/300 R300	74507	6,7
FOE-100 TE-450/450 R300	74508	7,8
FOE-100 TE-600/600 R300	74509	9,0
FOE-100 TE-750/750 R300	74510	10,4
FOE-100 TE-900/900 R300	74511	11,4

Radius 600 mm

Type Description	FRP	FRP (kg)
FOE-100 TE-150/150 R600	73142	8,8
FOE-100 TE-300/300 R600	73143	10,0
FOE-100 TE-450/450 R600	73144	11,5
FOE-100 TE-600/600 R600	73145	12,9
FOE-100 TE-750/750 R600	73146	14,8
FOE-100 TE-900/900 R600	73147	15,9

Cross-Piece

Compact design Cross-Piece Fitting in composite system. (For more radius options and for unequal fittings please contact us.)



Radius 300 mm

Type Description	FRP	FRP (kg)
FOE-100 CP-150/150 R300	70314	8,1
FOE-100 CP-300/300 R300	70315	8,9
FOE-100 CP-450/450 R300	70316	10,1
FOE-100 CP-600/600 R300	70317	11,2
FOE-100 CP-750/750 R300	70318	12,6
FOE-100 CP-900/900 R300	70319	13,6

Radius 600 mm

Type Description	FRP	FRP (kg)
FOE-100 CP-150/150 R600	71784	12,3
FOE-100 CP-300/300 R600	71785	13,6
FOE-100 CP-450/450 R600	71786	15,2
FOE-100 CP-600/600 R600	71787	16,7
FOE-100 CP-750/750 R600	71788	18,5
FOE-100 CP-900/900 R600	71789	19,9

Riser Part

Riser Link which can be combined with Angle Plates and additional Riser Links to create required configurations.

Type Description	FRP	FRP (kg)
FOE-100 RI-PA-150	74160	1,0
FOE-100 RI-PA-300	74161	1,1
FOE-100 RI-PA-450	74162	1,2
FOE-100 RI-PA-600	74163	1,3
FOE-100 RI-PA-750	74164	1,4
FOE-100 RI-PA-900	74165	1,5



Inside Fixed Riser 90°. Radius 400 mm

Fixed angle Inside Riser piece. Compact design. Preassembled in composite system. Exact radius 434 mm.

Type Description	FRP	FRP (kg)
FOE-100 RI-IN-90-150 R400	74236	2,0
FOE-100 RI-IN-90-300 R400	74237	2,1
FOE-100 RI-IN-90-450 R400	74238	2,2
FOE-100 RI-IN-90-600 R400	74239	2,3
FOE-100 RI-IN-90-750 R400	74240	2,4
FOE-100 RI-IN-90-900 R400	74241	2,5

8 Locking Bolt set(s) M10x20 included.



Inside Fixed Riser 90°. Radius 600 mm

Fixed angle Inside Riser piece. Compact design. Preassembled in composite system. Exact radius 633 mm.

Type Description	FRP	FRP (kg)
FOE-100 RI-IN-90-150 R600	74242	3,4
FOE-100 RI-IN-90-300 R600	74243	3,6
FOE-100 RI-IN-90-450 R600	74244	3,8
FOE-100 RI-IN-90-600 R600	74245	4,0
FOE-100 RI-IN-90-750 R600	74246	4,3
FOE-100 RI-IN-90-900 R600	74247	4,4

8 Locking Bolt set(s) M10x20 included.



Inside Fixed Riser 90°. Radius 800 mm

Fixed angle Inside Riser piece. Compact design. Preassembled in composite system. Exact radius 831 mm.

Type Description	FRP	FRP (kg)
FOE-100 RI-IN-90-150 R800	74248	4,8
FOE-100 RI-IN-90-300 R800	74249	5,1
FOE-100 RI-IN-90-450 R800	74250	5,4
FOE-100 RI-IN-90-600 R800	74251	5,8
FOE-100 RI-IN-90-750 R800	74252	6,1
FOE-100 RI-IN-90-900 R800	74253	6,3

8 Locking Bolt set(s) M10x20 included.



Outside Fixed Riser 90°. Radius 400 mm

Fixed angle Outside Riser piece. Compact design. Preassembled in composite system. Exact radius 393 mm.

Type Description	FRP	FRP (kg)
FOE-100 RI-OU-90-150 R400	74254	2,0
FOE-100 RI-OU-90-300 R400	74255	2,1
FOE-100 RI-OU-90-450 R400	74256	2,2
FOE-100 RI-OU-90-600 R400	74257	2,3
FOE-100 RI-OU-90-750 R400	74258	2,4
FOE-100 RI-OU-90-900 R400	74259	2,5

8 Locking Bolt set(s) M10x20 included.



Outside Fixed Riser 90°. Radius 600 mm

Fixed angle Outside Riser piece. Compact design. Preassembled in composite system. Exact radius 593 mm.

Type Description	FRP	FRP (kg)
FOE-100 RI-OU-90-150 R600	74260	3,4
FOE-100 RI-OU-90-300 R600	74261	3,6
FOE-100 RI-OU-90-450 R600	74262	3,8
FOE-100 RI-OU-90-600 R600	74263	4,0
FOE-100 RI-OU-90-750 R600	74264	4,3
FOE-100 RI-OU-90-900 R600	74265	4,4

8 Locking Bolt set(s) M10x20 included.



Outside Fixed Riser 90°. Radius 800 mm

Fixed angle Outside Riser piece. Compact design. Preassembled in composite system. Exact radius 790 mm.

Type Description	FRP	FRP (kg)
FOE-100 RI-OU-90-150 R800	74266	4,8
FOE-100 RI-OU-90-300 R800	74267	5,1
FOE-100 RI-OU-90-450 R800	74268	5,4
FOE-100 RI-OU-90-600 R800	74269	5,8
FOE-100 RI-OU-90-750 R800	74270	6,1
FOE-100 RI-OU-90-900 R800	74271	6,3

8 Locking Bolt set(s) M10x20 included.



Reducer Right

Part for reducing cable ladder width in set increments from one side.

Type Description	FRP	FRP (kg)
FOE-100 RE-R-300/150	70371	3,4
FOE-100 RE-R-450/150	70372	4,1
FOE-100 RE-R-600/150	70373	5,2
FOE-100 RE-R-450/300	70374	3,8
FOE-100 RE-R-600/300	70375	4,4
FOE-100 RE-R-750/300	70376	5,6
FOE-100 RE-R-900/300	71449	6,3
FOE-100 RE-R-600/450	70377	4,1
FOE-100 RE-R-750/450	70378	4,7
FOE-100 RE-R-900/450	70379	6,0
FOE-100 RE-R-750/600	70380	4,4
FOE-100 RE-R-900/600	70381	5,1
FOE-100 RE-R-900/750	110124	4,7



Reducer Left

Part for reducing cable ladder width in set increments from one side.

Type Description	FRP	FRP (kg)
FOE-100 RE-L-300/150	70349	3,5
FOE-100 RE-L-450/150	70350	4,0
FOE-100 RE-L-600/150	70351	5,2
FOE-100 RE-L-450/300	70352	3,7
FOE-100 RE-L-600/300	70353	4,4
FOE-100 RE-L-750/300	70354	5,5
FOE-100 RE-L-900/300	71448	6,3
FOE-100 RE-L-600/450	70355	-
FOE-100 RE-L-750/450	70356	4,7
FOE-100 RE-L-900/450	70357	5,9
FOE-100 RE-L-750/600	70358	4,3
FOE-100 RE-L-900/600	70359	5,0
FOE-100 RE-L-900/750	110125	4,7



Reducer Central

Part for reducing cable ladder width equally from both sides in set increments.

Type Description	FRP	FRP (kg)
FOE-100 RE-300/150	70327	3,4
FOE-100 RE-450/150	70328	4,2
FOE-100 RE-600/150	70329	4,6
FOE-100 RE-450/300	70330	3,6
FOE-100 RE-600/300	70331	4,5
FOE-100 RE-750/300	70332	5,0
FOE-100 RE-900/300	71447	5,4
FOE-100 RE-600/450	70333	3,8
FOE-100 RE-750/450	70334	4,8
FOE-100 RE-900/450	70335	5,1
FOE-100 RE-750/600	70336	-
FOE-100 RE-900/600	70337	5,1
FOE-100 RE-900/750	110121	4,3



FOE100 Fixings

Splice plates are delivered in a set for one side of each ladder, complete with bolts as shown. Two sets are therefore required for a ladder connection.

All standard splice connectors in both SS and FRP material are supplied with SS fasteners.

Splice Connector

Splice Connector for connecting Cable Ladders and Fittings.

Type Description	Fasteners included	SS	SS (kg)	FRP
FOE-100 SC	4×M10	74858	0,30	75051



Splice Angle Horizontal

Horizontal 90° splice for FOE cable ladders. Note that the SS type is supplied as flat plate which may be bent to any angle.

Type Description	Fasteners included	SS	SS (kg)	FRP
FOE-100 SA-HO	4×M10	74861	0,30	70400



Hinge Vertical

Vertical Hinge for FOE Cable Ladders in two types. The heavy duty SS version can be locked in place in increments of 4°.

Type Description	Fasteners included	SS	SS (kg)	FRP
FOE-100 HV-HD	6×M10	74864	0,40	75036



Splice Angle Plate 22.5°

Vertical splice plates can be used to quickly construct risers at various angles.

Type Description	Fasteners included	SS	SS (kg)	FRP
FOE-100 SA-VE-22.5	4×M10	74197	0,20	70413



Splice Angle Plate 30°

Vertical splice plates can be used to quickly construct risers at various angles.

Type Description	Fasteners included	SS	SS (kg)	FRP
FOE-100 SA-VE-30	4×M10	74194	0,20	70410



Splice Angle Plate 45°

Vertical splice plates can be used to quickly construct risers at various angles.

Type Description	Fasteners included	SS	SS (kg)	FRP
FOE-100 SA-VE-45	4×M10	74191	0,30	70407



Reducer Part

Part for increasing or reducing Cable Ladder width in set increments. Universal design which can be used for left or right side independently or both sides together. When fitting on just one side, one additional splice connector is required (ordered separately).



Type Description	FRP	FRP (kg)
FOE-100 RP-150	70275	0,70
FOE-100 RP-300	70276	0,90
FOE-100 RP-450	70277	1,1
FOE-100 RP-600	70278	1,3
FOE-100 RP-750	70279	1,6

4 Locking Bolt set(s) M10x20 included.

End Cover

End Cover to close the end of the Cable Ladder. Provides a tidy finish.



Type Description	FRP	FRP (kg)
FOE-100 EC-150	74701	0,10
FOE-100 EC-300	74702	0,20
FOE-100 EC-450	74703	0,30
FOE-100 EC-600	74704	0,40
FOE-100 EC-750	74705	0,60
FOE-100 EC-900	74706	0,70

2 ST4.8x13 Self Tapping Screw(s) included.

Dividers

Divider for FOE100 Cable Ladder. Supplied in 3 m lengths. Dividers are used for separation and segregation of different systems.



Type Description	Fasteners included	FRP	FRP (kg)
FOE 100 FTE-80 DI	4xM6	74541	1,6

FOE150 GA Cable Ladder System

FOE150 GA Cable Ladder System

Composite Cable Ladder System with 150 mm rail height, certified to Nema 16B according to Nema FG-1 standard. To specify FOE150 GA fittings, simply add the suffix "GA" after the article number of the FOE150 fittings.

Type Description	FRP	FRP (kg)
FOE-150GA-CL-150-3000	70264	14,6
FOE-150GA-CL-300-3000	70265	15,7
FOE-150GA-CL-450-3000	70266	16,6
FOE-150GA-CL-600-3000	70267	17,9
FOE-150GA-CL-750-3000	70268	18,7
FOE-150GA-CL-900-3000	70269	19,8



FOE150 HD Cable Ladder System

FOE150 Cable Ladder

Composite Cable Ladder System with 150 mm rail height, certified to Nema 20C according to Nema FG-1 standard.



FOE150 Cable Ladder in 3 m length

Type Description	FRP	FRP (kg)
FOE-150 CL-150-3000	74437	18,7
FOE-150 CL-300-3000	74438	19,8
FOE-150 CL-450-3000	74439	20,8
FOE-150 CL-600-3000	74440	22,0
FOE-150 CL-750-3000	74441	23,1
FOE-150 CL-900-3000	74442	23,9

FOE150 Cable Ladder in 6 m length

Type Description	FRP	FRP (kg)
FOE-150 CL-150-6000	74752	37,5
FOE-150 CL-300-6000	74753	39,6
FOE-150 CL-450-6000	74754	41,6
FOE-150 CL-600-6000	74755	44,0
FOE-150 CL-750-6000	74756	46,3
FOE-150 CL-900-6000	74757	47,9

FOE150 Fittings

90° Flat Elbow

Compact design Flat Elbow in composite system.
(For more radius options please contact us.)



Radius 300 mm

Type Description	FRP	FRP (kg)
FOE-150 FE-90-150 R300	74612	6,9
FOE-150 FE-90-300 R300	74613	8,0
FOE-150 FE-90-450 R300	74614	9,9
FOE-150 FE-90-600 R300	74615	11,2
FOE-150 FE-90-750 R300	74616	12,5
FOE-150 FE-90-900 R300	74617	13,7

Radius 600 mm

Type Description	FRP	FRP (kg)
FOE-150 FE-90-150 R600	73112	10,2
FOE-150 FE-90-300 R600	73113	11,4
FOE-150 FE-90-450 R600	73114	12,7
FOE-150 FE-90-600 R600	73115	14,6
FOE-150 FE-90-750 R600	73116	15,9
FOE-150 FE-90-900 R600	73117	17,2

45° Flat Elbow

Compact design Flat Elbow in composite system.
(For more radius options please contact us.)



Radius 300 mm

Type Description	FRP	FRP (kg)
FOE-150 FE-45-150 R300	74630	4,4
FOE-150 FE-45-300 R300	74631	5,0
FOE-150 FE-45-450 R300	74632	6,0
FOE-150 FE-45-600 R300	74633	6,7
FOE-150 FE-45-750 R300	74634	7,6
FOE-150 FE-45-900 R300	74635	8,1

Radius 600 mm

Type Description	FRP	FRP (kg)
FOE-150 FE-45-150 R600	73130	-
FOE-150 FE-45-300 R600	73131	6,2
FOE-150 FE-45-450 R600	73132	7,3
FOE-150 FE-45-600 R600	73133	7,7
FOE-150 FE-45-750 R600	73134	8,5
FOE-150 FE-45-900 R600	73135	9,2

Tee-Piece

Compact design Tee-Piece Fitting in composite system.
(For more radius options and for unequal fittings please contact us.)



Radius 300 mm

Type Description	FRP	FRP (kg)
FOE-150 TE-150/150 R300	74512	10,2
FOE-150 TE-300/300 R300	74513	11,1
FOE-150 TE-450/450 R300	74514	12,8
FOE-150 TE-600/600 R300	74515	14,4
FOE-150 TE-750/750 R300	74516	16,1
FOE-150 TE-900/900 R300	74517	17,1

Radius 600 mm

Type Description	FRP	FRP (kg)
FOE-150 TE-150/150 R600	73148	15,7
FOE-150 TE-300/300 R600	73149	17,0
FOE-150 TE-450/450 R600	73150	18,8
FOE-150 TE-600/600 R600	73151	20,7
FOE-150 TE-750/750 R600	73152	22,8
FOE-150 TE-900/900 R600	73153	24,4

Cross Piece

Compact design Cross-Piece Fitting in composite system.
(For more radius options and for unequal fittings please contact us.)



Radius 300 mm

Type Description	FRP	FRP (kg)
FOE-150 CP-150/150 R300	70320	14,0
FOE-150 CP-300/300 R300	70321	15,0
FOE-150 CP-450/450 R300	70322	16,2
FOE-150 CP-600/600 R300	70323	17,4
FOE-150 CP-750/750 R300	70324	18,9
FOE-150 CP-900/900 R300	70325	20,1

Radius 600 mm

Type Description	FRP	FRP (kg)
FOE-150 CP-150/150 R600	71676	21,4
FOE-150 CP-300/300 R600	71677	22,8
FOE-150 CP-450/450 R600	71678	24,5
FOE-150 CP-600/600 R600	71679	26,1
FOE-150 CP-750/750 R600	71680	28,0
FOE-150 CP-900/900 R600	71681	29,6

Riser Part

Riser Link which can be combined with Angle Plates and additional Riser Links to create required configurations. Preassembled in composite system.

Type Description	FRP	FRP (kg)
FOE-150 RI-PA-150	74166	1,8
FOE-150 RI-PA-300	74167	1,9
FOE-150 RI-PA-450	74168	2,0
FOE-150 RI-PA-600	74169	2,2
FOE-150 RI-PA-750	74170	2,3
FOE-150 RI-PA-900	74171	2,4



Inside Fixed Riser 90°. Radius 400 mm

Fixed angle Inside Riser piece. Compact design. Preassembled in composite system. Exact radius 482 mm.

Type Description	FRP	FRP (kg)
FOE-150 RI-IN-90-150 R400	74272	3,3
FOE-150 RI-IN-90-300 R400	74273	3,4
FOE-150 RI-IN-90-450 R400	74274	3,5
FOE-150 RI-IN-90-600 R400	74275	3,6
FOE-150 RI-IN-90-750 R400	74276	3,7
FOE-150 RI-IN-90-900 R400	74277	3,8

8 Locking Bolt set(s) M10x20 included.



Inside Fixed Riser 90°. Radius 600 mm

Fixed angle Inside Riser piece. Compact design. Preassembled in composite system. Exact radius 680 mm.

Type Description	FRP	FRP (kg)
FOE-150 RI-IN-90-150 R600	74278	5,7
FOE-150 RI-IN-90-300 R600	74279	5,9
FOE-150 RI-IN-90-450 R600	74280	6,0
FOE-150 RI-IN-90-600 R600	74281	6,3
FOE-150 RI-IN-90-750 R600	74282	6,5
FOE-150 RI-IN-90-900 R600	74283	6,7

8 Locking Bolt set(s) M10x20 included.



Inside Fixed Riser 90°. Radius 800 mm

Fixed angle Inside Riser piece. Compact design. Preassembled in composite system. Exact radius 878 mm.

Type Description	FRP	FRP (kg)
FOE-150 RI-IN-90-150 R800	74284	8,0
FOE-150 RI-IN-90-300 R800	74285	8,3
FOE-150 RI-IN-90-450 R800	74286	8,6
FOE-150 RI-IN-90-600 R800	74287	9,0
FOE-150 RI-IN-90-750 R800	74288	9,3
FOE-150 RI-IN-90-900 R800	74289	9,6

8 Locking Bolt set(s) M10x20 included.



Outside Fixed Riser 90°. Radius 400 mm

Fixed angle Outside Riser piece. Compact design. Preassembled in composite system. Exact radius 393 mm.

Type Description	FRP	FRP (kg)
FOE-150 RI-OU-90-150 R400	74290	3,3
FOE-150 RI-OU-90-300 R400	74291	3,4
FOE-150 RI-OU-90-450 R400	74292	3,5
FOE-150 RI-OU-90-600 R400	74293	3,6
FOE-150 RI-OU-90-750 R400	74294	3,7
FOE-150 RI-OU-90-900 R400	74295	3,8

8 Locking Bolt set(s) M10x20 included.



Outside Fixed Riser 90°. Radius 600 mm

Fixed angle Outside Riser piece. Compact design. Preassembled in composite system. Exact radius 591 mm.

Type Description	FRP	FRP (kg)
FOE-150 RI-OU-90-150 R600	74296	5,7
FOE-150 RI-OU-90-300 R600	74297	5,9
FOE-150 RI-OU-90-450 R600	74298	6,0
FOE-150 RI-OU-90-600 R600	74299	6,3
FOE-150 RI-OU-90-750 R600	74300	6,5
FOE-150 RI-OU-90-900 R600	74301	6,7

8 Locking Bolt set(s) M10x20 included.



Outside Fixed Riser 90°. Radius 800 mm

Fixed angle Outside Riser piece. Compact design. Preassembled in composite system. Exact radius 800 mm.

Type Description	FRP	FRP (kg)
FOE-150 RI-OU-90-150 R800	74302	8,0
FOE-150 RI-OU-90-300 R800	74303	8,3
FOE-150 RI-OU-90-450 R800	74304	8,6
FOE-150 RI-OU-90-600 R800	74305	9,0
FOE-150 RI-OU-90-750 R800	74306	9,3
FOE-150 RI-OU-90-900 R800	74307	9,6

8 Locking Bolt set(s) M10x20 included.



Reducer Right

Part for reducing Cable Ladder width in set increments from one side.

Type Description	FRP	FRP (kg)
FOE-150 RE-R-300/150	70382	5,9
FOE-150 RE-R-450/150	70383	7,1
FOE-150 RE-R-600/150	70384	8,7
FOE-150 RE-R-450/300	70385	6,2
FOE-150 RE-R-600/300	70386	7,5
FOE-150 RE-R-750/300	70387	9,1
FOE-150 RE-R-900/300	71452	10,4
FOE-150 RE-R-600/450	70388	6,6
FOE-150 RE-R-750/450	70389	7,8
FOE-150 RE-R-900/450	70390	9,6
FOE-150 RE-R-750/600	70391	6,9
FOE-150 RE-R-900/600	70392	8,1
FOE-150 RE-R-900/750	110130	-



Reducer Left

Part for reducing Cable Ladder width in set increments from one side.

Type Description	FRP	FRP (kg)
FOE-150 RE-L-300/150	70360	5,8
FOE-150 RE-L-450/150	70361	7,1
FOE-150 RE-L-600/150	70362	8,6
FOE-150 RE-L-450/300	70363	6,2
FOE-150 RE-L-600/300	70364	7,5
FOE-150 RE-L-750/300	70365	9,1
FOE-150 RE-L-900/300	71451	10,4
FOE-150 RE-L-600/450	70366	6,6
FOE-150 RE-L-750/450	70367	7,8
FOE-150 RE-L-900/450	70368	9,6
FOE-150 RE-L-750/600	70369	6,9
FOE-150 RE-L-900/600	70370	8,1
FOE-150 RE-L-900/750	110131	7,0



Reducer Central

Part for reducing Cable Ladder width equally from both sides in set increments.

Type Description	FRP	FRP (kg)
FOE-150 RE-300/150	70338	5,8
FOE-150 RE-450/150	70339	6,9
FOE-150 RE-600/150	70340	7,7
FOE-150 RE-450/300	70341	6,0
FOE-150 RE-600/300	70342	7,2
FOE-150 RE-750/300	70343	8,0
FOE-150 RE-900/300	71450	8,8
FOE-150 RE-600/450	70344	6,2
FOE-150 RE-750/450	70345	7,5
FOE-150 RE-900/450	70346	8,3
FOE-150 RE-750/600	70347	6,4
FOE-150 RE-900/600	70348	7,8
FOE-150 RE-900/750	110127	6,6



FOE150 Fixings

Splice plates are delivered in a set for one side of each ladder, complete with bolts as shown. Two sets are therefore required for a ladder connection.

All standard splice connectors in both SS and FRP material are supplied with SS fasteners.

Splice Connector

Splice Connector for connecting Cable Ladders and Fittings.

Type Description	Fasteners included	SS	SS (kg)	FRP
FOE-150 SC	4×M10	74859	0,50	75045



Splice Angle Horizontal/Expansion Couple

Horizontal 90° Splice for FOE Cable Ladders.

Type Description	Fasteners included	SS	SS (kg)	FRP
FOE-150 SA-HO	4×M10	74862	0,60	70401



Hinge Vertical

Vertical Hinge for FOE Cable Ladders.

Type Description	Fasteners included	SS	SS (kg)	FRP
FOE-150 SV-HD	6×M10	74865	0,80	75037



Splice Angle Plate 22.5°

Vertical Splice Plates for quickly and accurate construction of Risers at various angles.

Type Description	Fasteners included	SS	SS (kg)	FRP
FOE-150 SA-VE-22.5	4×M10	74198	0,30	70414



Splice Angle Plate 30°

Vertical Splice Plates for quickly and accurate construction of risers at various angles.

Type Description	Fasteners included	SS	SS (kg)	FRP
FOE-150 SA-VE-30	4×M10	74195	0,30	70411



Splice Angle Plate 45°

Vertical Splice Plates for quickly and accurate construction of Risers at various angles.

Type Description	Fasteners included	SS	SS (kg)	FRP
FOE-150 SA-VE-45	4×M10	74192	0,40	70408



Reducer Part

Part for increasing or reducing Cable Ladder width in set increments. Universal design which can be used for left or right side independently or both sides together. When fitting on just one side, one additional splice connector is required (ordered separately).

Type Description	FRP	FRP (kg)
FOE-150 RP-150	70280	1,0
FOE-150 RP-300	70281	1,5
FOE-150 RP-450	70282	1,9
FOE-150 RP-600	70283	2,4
FOE-150 RP-750	70284	2,8

4 Locking Bolt set(s) M10x25 included.



End Cover

End Cover to close the end of the Cable Ladder. Provides a tidy finish.

Type Description	FRP	FRP (kg)
FOE-150 EC-150	74707	0,20
FOE-150 EC-300	74708	0,30
FOE-150 EC-450	74709	0,50
FOE-150 EC-600	74710	0,60
FOE-150 EC-750	74711	0,80
FOE-150 EC-900	74712	0,90

2 ST4.8x13 Self Tapping Screw(s) included.



Divider

Divider for FOE-150 Cable Ladder. Supplied in 3 m lengths. Dividers are used for separation and segregation of different systems.

Type Description	Fasteners included	FRP	FRP (kg)
FOE-150 DI	4xM6	74542	2,5



FOE Cover

Cover Straight

Flat cover for the FOE100 and FOE150 cable ladder system. Covers are supplied in 3 m lengths, consisting of 4 interlocking sections.

Type Description	FRP	FRP (kg)
FOE CO-CL-150	71468	3,7
FOE CO-CL-300	71470	6,7
FOE CO-CL-450	71472	9,8
FOE CO-CL-600	71474	12,8
FOE CO-CL-750	71475	15,9
FOE CO-CL-900	71476	18,9

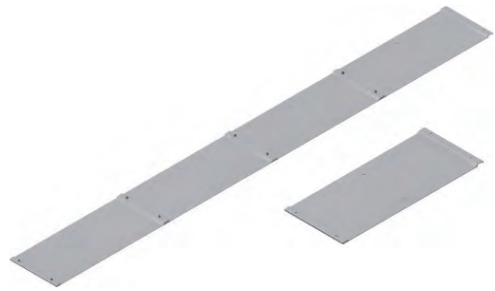

Cover for 90° Flat Elbow. Radius 300 mm

Flat cover for FOE 90° Flat Elbow in composite system for FOE100 and FOE150. Radius 300 mm. (For more radius options please contact us.)

Type Description	FRP	FRP (kg)
FOE-CO FE-90-150 R3	74715	1,1
FOE-CO FE-90-300 R3	74716	2,3
FOE-CO FE-90-450 R3	74717	3,6
FOE-CO FE-90-600 R3	74718	5,3
FOE-CO FE-90-750 R3	74719	7,1
FOE-CO FE-90-900 R3	74720	9,1



Cover for 45° Flat Elbow. Radius 300 mm

Flat cover for FOE 45° Flat Elbow in composite system for FOE100 and FOE150. Radius 300 mm. (For more radius options please contact us.)

Type Description	FRP	FRP (kg)
FOE-CO FE-45-150 R3	74801	0,60
FOE-CO FE-45-300 R3	74802	1,2
FOE-CO FE-45-450 R3	74803	2,0
FOE-CO FE-45-600 R3	74804	3,1
FOE-CO FE-45-750 R3	74805	4,2
FOE-CO FE-45-900 R3	74806	5,3



Cover FOE Tee-Piece. Radius 300 mm

Flat cover for the FOE100 and FOE150 cable ladder system.
(For more radius options or for unequal cover please contact us.)

Type Description	FRP	FRP (kg)
FOE CO-TE-150 R3	74721	2,0
FOE CO-TE-300 R3	74722	3,5
FOE CO-TE-450 R3	74723	5,4
FOE CO-TE-600 R3	74724	7,6
FOE CO-TE-750 R3	74725	9,9
FOE CO-TE-900 R3	74726	12,6

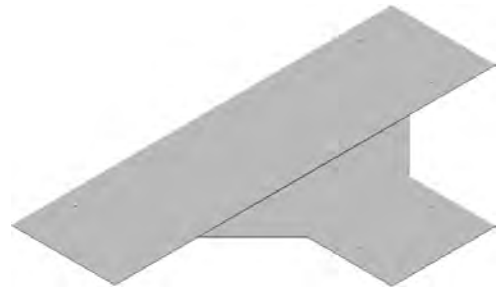

Cover FOE Cross-Piece. Radius 300 mm.

Flat cover for the FOE100 and FOE150 cable ladder system.
(For more radius options or for unequal cover please contact us.)

Type Description	FRP	FRP (kg)
FOE CO CP-150 R3	71655	2,5
FOE CO CP-300 R3	71656	4,9
FOE CO CP-450 R3	71657	7,2
FOE CO CP-600 R3	71658	9,8
FOE CO CP-750 R3	71659	12,7
FOE CO CP-900 R3	71660	15,7



Cover Riser

Riser cover for the FOE100 and FOE150 cable ladder system. For Radius R400, 1 x cover are required. For Radius R600, 2 x cover are required. For Radius R800, 3 x cover are required.

Type Description	FRP	FRP (kg)
FOE CO-FR-150	74760	0,30
FOE CO-FR-300	74761	0,60
FOE CO-FR-450	74762	0,80
FOE CO-FR-600	74763	1,1
FOE CO-FR-750	74764	1,4
FOE CO-FR-900	74765	1,6



FOE Cover Clamps

HD Cover Fixing Clamp FOE

Heavy duty cover clamp for straight sections of cable ladder cover. Utilizes bolt set that it supplied as part of straight cover.

Type Description	Fasteners included	SS	SS (kg)	FRP
FOE-100 CC-HD	-	71485	0,090	71783
FOE-150 CC-HD	-	71486	0,10	71757



GP Cover Fixing Clamp FOE

Lightweight cable ladder cover fixing clamp.

Type Description	Fasteners included	SS	SS (kg)	FRP
FOE CC	1xM6	74856	0,060	72077



HD Flexi Cover Fixing Clamp FOE

HD Flexi Cover Clamps are available for 100 and 150 mm heights.

Type Description	FRP/SS	FRP/SS (kg)
FOE-100-150	71617	0,30
FOE-100-300	71618	0,40
FOE-100-450	71619	0,50
FOE-100-600	71620	0,60
FOE-100-750	71621	0,70
FOE-100-900	71622	0,80
FOE-150-150	71623	0,30
FOE-150-300	71624	0,40
FOE-150-450	71625	0,50
FOE-150-600	71626	0,60
FOE-150-750	71627	0,70
FOE-150-900	71628	0,80



2 Locking Bolt set(s) M6x25 included.

FOE Accessories

Smart Jig

With this jig you can pre-drill holes in exact positions when cutting cable ladder lengths on-site. After modifications use Oglænd System Sealing Kit to preserve the product quality.

Type Description	SS	SS (kg)
FOE-DJ70/100/150	74398	0,40

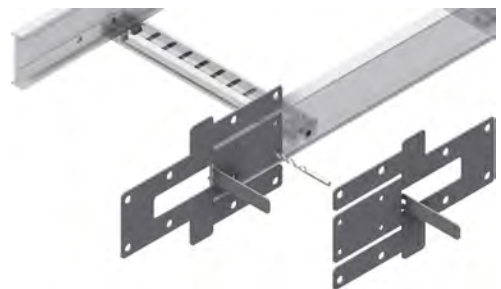

Fixing Clamp

Fixing Clamp which fits both ladders and trays. Used for vertical or horizontal installations.

Type Description	Fasteners included	SS	SS (kg)	FRP
FOE/FTE FC-B40x65	1xM10	74783	0,040	72024



Expansion Clamp

Fixing clamp suitable for all cable ladder heights. Used for horizontal installations. Compatible with M10 fasteners.

Type Description	Fasteners included	FRP	FRP (kg)
FOE FC-A40x65	-	71410	0,040

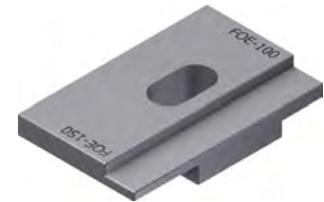

Rung FOE70

Punched rung for use with FOE70 cable ladders. Rung supplied complete with Smartlok insert and SS bolts.

Type Description	FRP	FRP (kg)
FOE-70 RU-150	71544	0,10
FOE-70 RU-200	71545	0,10
FOE-70 RU-300	71546	0,20
FOE-70 RU-400	71547	0,20
FOE-70 RU-450	71548	0,20
FOE-70 RU-500	71549	0,20
FOE-70 RU-600	71550	0,30



Rung FOE100 and FOE150

Additional rungs can be added to standard FOE ladder. Rung supplied complete with Smartlok insert and SS bolts.

Type Description	FRP	FRP (kg)
FOE RU-150	74469	0,20
FOE RU-300	74470	0,30
FOE RU-450	74471	0,40
FOE RU-600	74472	0,50
FOE RU-750	74473	0,60
FOE RU-900	74474	0,70



SmartCleat Adapter

Adapter for fixing SmartCleats to FOE rungs. Produced in FRP.

Type Description	FRP	FRP (kg)
A-AD-RU-FRP	71215	0,050



Exit Plate

Exit plate for cable ladders.

Type Description	FRP	FRP (kg)
FOE EX-150	74545	0,40



FTE COMPOSITE CABLE TRAY SYSTEM

Oglaend System corrosion resistant fibre reinforced plastic FRP cable trays are designed to deliver weight reductions while maintaining strength and maximising loading capability. The design delivers HSE improvements when lifting and fitting tray and support equipment. The cable trays are available in five different resin materials, each formulated to satisfy special project requirements.

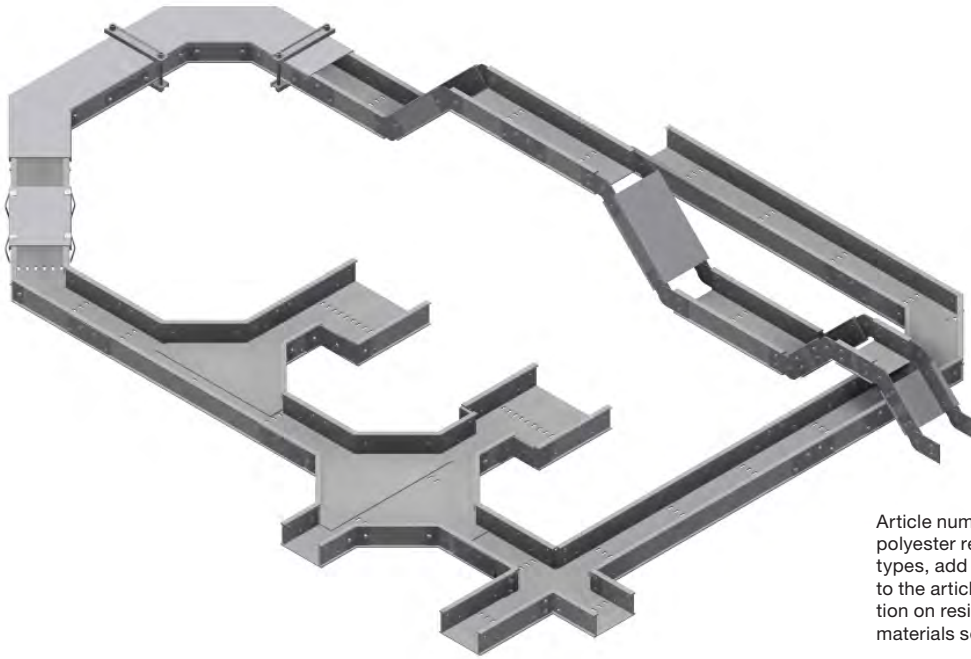

Article numbers are for standard FRP polyester resin. For alternative resin types, add the resin code as a suffix to the article number. For more information on resin systems, please see the materials section or refer to our website.



MATERIALS



3D LIBRARIES

AVEVA (E3D / PDMS)
Hexagon (Intergraph Smart 3D)
Bentley

CERTIFICATES & DECLARATIONS

Type	 UL/CUL	 CE
FTE50	Standard resin ¹	Standard resin
FTE80	Standard resin ¹	Standard resin

¹Up to 400mm wide. ²Up to 300mm wide.

CABLE TRAYS



FTE50

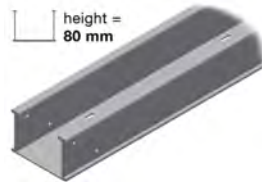

FTE80

LOAD DATA

Cable Tray	Tray Height (mm)	Loading Depth (mm)	SWL 2 m FRP (kg/m)	SWL 3 m FRP (kg/m)	Wall thickness FRP (mm)
FTE50	50	47	70*	59*	3 ¹ , 4 ² or 5 ³
FTE80	80	77	113*	103*	3 ¹ , 4 ² or 5 ³

SWL = Safe Working Load.

Loading data according to IEC61537. The length of the end span must be reduced to 3/4 of the support spacing and with no splices on the end span.

*Tested without underside splice connector. ¹FTE50 50 mm wide. ²FTE50 100-200 mm, FTE80 50-150 mm. ³FTE50 300-600 mm, FTE80 200-600 mm.

DIFFERENT HEIGHTS (MM):

Different tray heights to give more choice for loading space availability. Designed with unique I-beam for superior loading capacity.



AVAILABLE WIDTHS (MM):

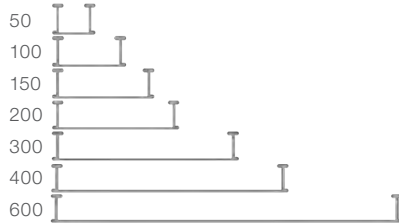

FITTING ACCESSORIES AVAILABLE IN FRP AND SS
Product can be supplied in full FRP.



PRE-SLOTTED TRAY

Saves drilling time. Compatible with ETIN™ Tubing Clamp.

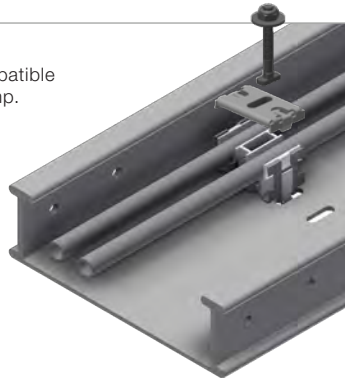

COVERS AND FIXING CLAMPS

Snap-on cover and heavy duty clamps.

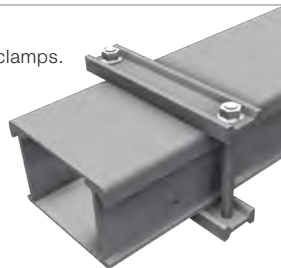

FE = Flat Elbow, TE = Tee-Piece, CP = Cross-Piece, CO = Cover

TABLE OF CONTENTS

FTE Smart Features..... 66

FTE50 Cable Tray System

FTE50 Cable Tray System 67

FTE50 Fittings..... 67

FTE50 Fixings 69

FTE80 Cable Tray System

FTE80 Cable Tray System 71

FTE80 Fittings..... 71

FTE80 Fixings 73

FTE Cover & Accessories

FTE Cover 75

FTE Cover Clamps..... 77

FTE Accessories..... 78



Intellectual Property Rights
Please note that many of the products presented in this catalogue are protected by our intellectual property rights in the form of patents, registered designs and trademarks, and that we have made the strategic decision to police and enforce these rights in all relevant jurisdictions.

FTE Smart Features

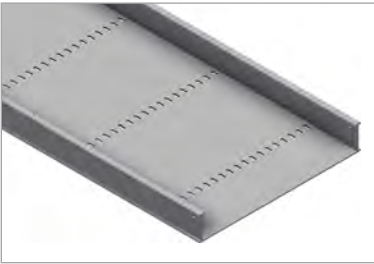

PERFORATED TRAY DESIGN

Perforations prohibit any liquid or chemical entrapment thus offering a long service life. Rounded edges for easy handling. Unique off centre beam profile design with increased load capacity that also reduces deflection.



SPLICE CONNECTORS

Full height splice and joint connectors can handle the same loadings as the tray system itself. Products are delivered with perforations for use with splice connectors predrilled.



EASY TO ATTACH TO SUPPORT SYSTEM

Easy installation and efficient support system attachment.



DRILL JIG

Smart jigs for easy and accurate drilling of perforations.



FLEXIBLE RISER

Flexible Riser, allows user to change between inside or outside riser. (simply remove then invert the splice angle plate).

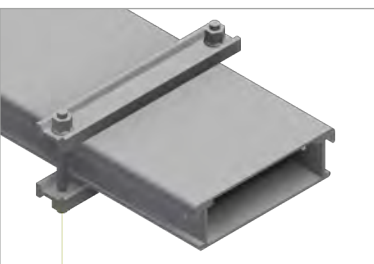

CABLE TRAY COVER

Covers are designed to snap on for widths up to 300 mm. This feature means that cover clamps are not required. For widths exceeding 300 mm or for exposed locations cover clamps are required. We offer a choice of SS cover clips or heavy duty FRP cover clamps.

FTE50 Cable Tray System

FTE50 Cable Tray

Composite Cable Tray suitable for Electrical and Instrumentation installations. Designed with unique I-beam for superior loading capacity. Tray height 50 mm. Supplied in 3 m lengths.

Type Description	FRP	FRP (kg)
FTE-50 CT-50	74400	3,9
FTE-50 CT-100	74401	5,3
FTE-50 CT-150	74399	6,1
FTE-50 CT-200	74402	7,0
FTE-50 CT-300	74403	9,2
FTE-50 CT-400	71460	13,6
FTE-50 CT-600	71558	19,2



FTE50 Fittings

90° Flat Elbow

Compact design Flat Elbow in composite system. Radius 250 mm. (For more radius options please contact us.)

Type Description	FRP	FRP (kg)
FTE-50 FE-90-50	74568	1,2
FTE-50 FE-90-100	74569	1,6
FTE-50 FE-90-150	74572	1,9
FTE-50 FE-90-200	74570	2,2
FTE-50 FE-90-300	74571	3,1
FTE-50 FE-90-400	71463	4,7
FTE-50 FE-90-600	71559	7,9



45° Flat Elbow

Compact design Flat Elbow in composite system. Radius 420 mm. (For more radius options please contact us.)

Type Description	FRP	FRP (kg)
FTE-50 FE-45-50	74575	0,80
FTE-50 FE-45-100	74576	1,1
FTE-50 FE-45-150	74574	1,3
FTE-50 FE-45-200	74577	1,5
FTE-50 FE-45-300	74578	2,0
FTE-50 FE-45-400	71464	3,0
FTE-50 FE-45-600	71560	4,9



Tee-Piece

Compact design Tee-Piece in composite system.

Type Description	FRP	FRP (kg)
FTE-50 TE-50/50	74660	0,60
FTE-50 TE-100/100	74661	0,90
FTE-50 TE-150/150	74659	1,1
FTE-50 TE-200/200	74662	1,3
FTE-50 TE-300/300	74663	1,9
FTE-50 TE-400/400	71465	3,2
FTE-50 TE-600/600	71561	5,8



Radius Tee-Piece

Compact design Tee-Piece with 300 mm radius in composite system.
(For more radius options please contact us.)

Type Description	FRP	FRP (kg)
FTE-50 TE-50/50 R300	71629	1,8
FTE-50 TE-100/100 R300	71630	2,4
FTE-50 TE-150/150 R300	71631	2,8
FTE-50 TE-200/200 R300	71632	3,2
FTE-50 TE-300/300 R300	71633	4,1
FTE-50 TE-400/400 R300	71634	6,4
FTE-50 TE-600/600 R300	71635	10,4



Combi Riser

Fixed 90° riser in composite system with splice plates in stainless steel. The splice plates can be rotated to create inside or outside risers.

Standard radius 40 0mm. (For more radius options please contact us.)

Type Description	FRP	FRP (kg)
FTE-50 CR-50	74670	0,60
FTE-50 CR-100	74671	0,80
FTE-50 CR-150	74669	0,90
FTE-50 CR-200	74672	0,90
FTE-50 CR-300	74673	1,2
FTE-50 CR-400	71490	1,6
FTE-50 CR-600	71562	2,2



4 Locking Bolt set(s) M6x16 included.

Reducer

Part for increasing or reducing Cable Tray width in set increments. Universal design which can be used for left or right side independently or both sides together. When fitting on just one side, one additional splice connector is required (ordered separately).



Type Description	FRP	FRP (kg)
FTE-50 RP-50	70438	0,10
FTE-50 RP-100	70439	0,10
FTE-50 RP-150	70440	0,10
FTE-50 RP-200	70441	0,20
FTE-50 RP-300	71606	0,20

2 Locking Bolt set(s) M6x16 included.

FTE50 Fixings

Splice plates are delivered in a set for one side of each tray, complete with bolts as shown. Two sets are therefore required for a tray connection.

All standard splice connectors in both SS and FRP material are supplied with SS fasteners.

Splice Connector

Straight Splice Connectors used to connect lengths of FTE50 Cable Tray.

Type Description	Fasteners included	SS	SS (kg)	FRP
FTE-50 SC	2xM6	74880	0,10	75043



Splice Connector underside

Splice Plate for attaching two FTE Cable Trays together from the underside. Recommended as a reinforcement to standard Splice Connectors on tray widths 400 mm and above.

Type Description	Fasteners included	FRP	FRP (kg)
FTE U.SPL-400	6xM6	110168	0,70
FTE U.SPL-500	6xM6	110169	0,90
FTE U.SPL-600	6xM6	110170	1,0



Expansion Splice Plates

Expansion Splice Connector with elongated holes to accommodate thermal expansion.

Type Description	Fasteners included	SS	SS (kg)	FRP
FTE-50 SC EXP	2xM6	71691	0,10	71608



Hinge Vertical

Vertical Hinge connector. Allows for flexible riser configurations.

Type Description	Fasteners included	SS	SS (kg)	FRP
FTE-50 HV	2xM6/2xM6	74882	0,20	75044



Splice Angle Horizontal

90° Splice Angle connector.

Type Description	Fasteners included	SS	SS (kg)	FRP
FTE-50 SA-HO-90	2xM6	74870	0,10	70436



Splice Angle 45°

Vertical Splice Plates that can be used to construct risers.

Type Description	Fasteners included	SS	SS (kg)	FRP
FTE-50 SA-VE-45	2xM6	74872	0,10	75041



End Cover

The End Cover provides a tidy end point on the Cable Tray run.

Type Description	FRP	FRP (kg)
FTE-50 EC-50	74727	0,030
FTE-50 EC-100	74728	0,060
FTE-50 EC-150	74885	0,080
FTE-50 EC-200	74729	0,10
FTE-50 EC-300	74730	0,10
FTE-50 EC-400	71492	0,20
FTE-50 EC-600	71564	0,30



2 ST4.8x13 Self Tapping Screw(s) included.

Divider

Divider for FTE50 Cable Tray. Dividers are used for separation and segregation of different systems.

Type Description	Fasteners included	FRP	FRP (kg)
FTE-50 DI	4xM6	74540	1,2



FRP Step Down Splice Plate

Stepped Splice Connector for connecting FTE cable trays in 50 and 80 mm heights.

Type Description	Fasteners included	SS	SS (kg)
FTE-SD-SP-80-50	4xM6	71650	0,090



FTE80 Cable Tray System

FTE80 Cable Tray

Composite Cable Tray suitable for Electrical and Instrumentation installations. Designed with unique I-beam for superior loading capacity. Tray height 80 mm. Supplied in 3 m lengths.

Type Description	FRP	FRP (kg)
FTE-80 CT-50	74410	5,8
FTE-80 CT-100	74411	6,7
FTE-80 CT-150	74409	7,5
FTE-80 CT-200	74412	9,2
FTE-80 CT-300	74413	10,9
FTE-80 CT-400	71461	4,9
FTE-80 CT-500	72051	18,4
FTE-80 CT-600	73879	20,9



FTE80 Fittings

90° Flat Elbow

Compact design Flat Elbow in composite system. Radius 250 mm. (For more radius options please contact us.)

Type Description	FRP	FRP (kg)
FTE-80 FE-90-50	74582	1,8
FTE-80 FE-90-100	74583	2,0
FTE-80 FE-90-150	74581	2,4
FTE-80 FE-90-200	74584	3,0
FTE-80 FE-90-300	74585	3,7
FTE-80 FE-90-400	71493	5,4
FTE-80 FE-90-500	72078	7,2
FTE-80 FE-90-600	73902	8,8



45° Flat Elbow

Compact design Flat Elbow in composite system. Radius 420 mm. (For more radius options please contact us.)

Type Description	FRP	FRP (kg)
FTE-80 FE-45-50	74590	1,2
FTE-80 FE-45-100	74591	1,4
FTE-80 FE-45-150	74589	1,6
FTE-80 FE-45-200	74592	1,9
FTE-80 FE-45-300	74593	2,4
FTE-80 FE-45-400	71494	3,5
FTE-80 FE-45-500	72079	4,5
FTE-80 FE-45-600	73903	5,4



Tee-Piece

Compact design Tee-Piece in composite system.

Type Description	FRP	FRP (kg)
FTE-80 TE-50/50	74664	1,1
FTE-80 TE-100/100	74665	1,1
FTE-80 TE-150/150	74668	1,4
FTE-80 TE-200/200	74666	1,8
FTE-80 TE-300/300	74667	2,4
FTE-80 TE-400/400	71495	3,6
FTE-80 TE-500/500	72080	5,2
FTE-80 TE-600/600	73904	6,3



Radius Tee-Piece

Compact design Tee-Piece with 300 mm radius in composite system.
(For more radius options please contact us.)

Type Description	FRP	FRP (kg)
FTE-80 TE-50/50 R300	71636	2,5
FTE-80 TE-100/100 R300	71637	2,9
FTE-80 TE-150/150 R300	71638	3,1
FTE-80 TE-200/200 R300	71639	3,8
FTE-80 TE-300/300 R300	71640	4,8
FTE-80 TE-400/400 R300	71641	7,1
FTE-80 TE-500/500 R300	72081	9,1
FTE-80 TE-600/600 R300	73905	11,3



Combi Riser

Fixed 90° riser in composite system with splice plates in stainless steel. The splice plates can be rotated to create inside or outside risers.

Standard radius 400 mm. (For more radius options please contact us)

Type Description	FRP	FRP (kg)
FTE-80 CR-50	74674	1,1
FTE-80 CR-100	74675	1,1
FTE-80 CR-150	74678	1,2
FTE-80 CR-200	74676	1,4
FTE-80 CR-300	74677	1,6
FTE-80 CR-400	71496	2,0
FTE-80 CR-500	72083	2,3
FTE-80 CR-600	73906	2,6



? Locking Bolt set(s) M??x?? included.

Reducer

Part for increasing or reducing Cable Tray width in set increments. Universal design which can be used for left or right side independently or both sides together. When fitting on just one side, one additional splice connector is required (ordered separately).



Type Description	FRP	FRP (kg)
FTE-80 RP-50	70442	0,20
FTE-80 RP-100	70443	0,20
FTE-80 RP-150	70445	0,20
FTE-80 RP-200	70446	0,30
FTE-80 RP-300	71607	0,30

2 Locking Bolt set(s) M6x16 included.

FTE80 Fixings

Splice plates are delivered in a set for one side of each tray, complete with bolts as shown. Two sets are therefore required for a tray connection.

All standard splice connectors in both SS and FRP material are supplied with SS fasteners.

Splice Connector

Straight Splice Connectors used to connect lengths of FTE80 Cable Tray.

Type Description	Fasteners included	SS	SS (kg)	FRP
FTE-80 SC	4xM6	74881	0,20	75052



Splice Connector underside

Splice Plate for attaching two FTE Cable Trays together from the underside. Recommended as a reinforcement to standard Splice Connectors on tray widths 400 mm and above.

Type Description	Fasteners included	FRP	FRP (kg)
FTE U.SPL-400	6xM6	110168	0,70
FTE U.SPL-500	6xM6	110169	0,90
FTE U.SPL-600	6xM6	110170	1,0



Expansion Splice Plates

Expansion Splice Connector with elongated holes to accommodate thermal expansion.

Type Description	Fasteners included	SS	SS (kg)	FRP
FTE-80 SC EXP	4xM6	71692	0,20	71609



Hinge Vertical

Vertical Hinge connector, allows for flexible riser configurations.

Type Description	Fasteners included	SS	SS (kg)	FRP
FTE-80 HV	4xM6/2xM6	74883	0,30	75053



Splice Angle Horizontal

90° Splice Angle connector.

Type Description	Fasteners included	SS	SS (kg)	FRP
FTE-80 SA-HO-90	4xM6	74871	0,20	70437



Splice Angle 45°

Vertical Splice Plates that can be used to construct risers.

Type Description	Fasteners included	SS	SS (kg)	FRP
FTE-80 SA-VE-45	2xM6	74873	0,20	75042



End Cover

The end cover provides a tidy end point on the cable tray run.

Type Description	FRP	FRP (kg)
FTE-80 EC-50	74731	0,040
FTE-80 EC-100	74732	0,070
FTE-80 EC-150	74886	0,10
FTE-80 EC-200	74733	0,10
FTE-80 EC-300	74734	0,20
FTE-80 EC-400	71498	0,30
FTE-80 EC-500	72117	0,30
FTE-80 EC-600	73907	0,40

2 ST4.8x13 Self Tapping Screw(s) included.



Divider

Divider for FTE80 Cable Tray.

Dividers are used for separation and segregation of different systems.

Type Description	Fasteners included	FRP	FRP (kg)
FOE 100 FTE-80 DI	4xM6	74541	1,6



FRP Step Down Splice Plate

Stepped Splice Connector for connecting FTE cable trays in 50 and 80 mm heights.

Type Description	Fasteners included	SS	SS (kg)
FTE-SD-SP-80-50	4xM6	71650	0,090



FTE Cover

Cover Straight

Flat cover for the FTE cable tray system with snap-lock system for widths up to 300 mm. For widths over 300 mm or for exposed locations, cover clamps are required.

Type Description	FRP	FRP (kg)
FTE CO-CT-50	74450	2,2
FTE CO-CT-100	74451	3,1
FTE CO-CT-150	74449	3,9
FTE CO-CT-200	74452	4,7
FTE CO-CT-300	74453	6,4
FTE CO-CT-400	71462	7,2
FTE CO-CT-500	72084	8,9
FTE CO-CT-600	71570	10,6



90° Cover

Flat cover for the FTE cable tray system with snap-lock system for widths up to 300 mm. For widths over 300 mm or for exposed locations, cover clamps are required. Radius 250 mm. (For more radius options please contact us.)

Type Description	FRP	FRP (kg)
FTE CO-FE-90-50	74735	0,60
FTE CO-FE-90-100	74736	0,80
FTE CO-FE-90-150	74739	1,1
FTE CO-FE-90-200	74737	1,4
FTE CO-FE-90-300	74738	2,0
FTE CO-FE-90-400	71499	3,0
FTE CO-FE-90-500	72112	3,8
FTE CO-FE-90-600	71651	5,0



45° Cover

Flat cover for the FTE cable tray system with snap-lock system for widths up to 300 mm. For widths over 300 mm or for exposed locations, cover clamps are required. Radius 420 mm. (For more radius options please contact us.)

Type Description	FRP	FRP (kg)
FTE CO-FE-45-50	74940	0,40
FTE CO-FE-45-100	74941	0,60
FTE CO-FE-45-150	74944	0,80
FTE CO-FE-45-200	74942	0,90
FTE CO-FE-45-300	74943	1,4
FTE CO-FE-45-400	71500	1,8
FTE CO-FE-45-500	72113	2,4
FTE CO-FE-45-600	71652	3,0



Tee Cover

Flat cover for the FTE cable tray system with snap-lock system for widths up to 300 mm. For widths over 300 mm or for exposed locations, cover clamps are required.

Type Description	FRP	FRP (kg)
FTE-CO TE-50/50	74840	0,30
FTE-CO TE-100/100	74841	0,40
FTE-CO TE-150/150	74839	0,60
FTE-CO TE-200/200	74842	0,80
FTE-CO TE-300/300	74843	1,3
FTE-CO TE-400/400	71530	1,9
FTE-CO TE-500/500	72115	2,6
FTE-CO TE-600/600	71573	0,30



Cover Combi Riser

Flat cover for the FTE cable tray system with snap-lock system for widths up to 300 mm. For widths over 300 mm or for exposed locations, cover clamps are required. Radius 400 mm. (For more radius options please contact us.)

Type Description	FRP	FRP (kg)
FTE-CO-CR-50	74844	0,20
FTE-CO-CR-100	74845	0,30
FTE-CO-CR-150	74848	0,40
FTE-CO-CR-200	74846	0,50
FTE-CO-CR-300	74847	0,70
FTE-CO-CR-400	71531	0,70
FTE-CO-CR-500	72114	0,90
FTE-CO-CR-600	71653	1,1



FTE Cover Clamps

Cover Clip FTE50

Quick and easy clip-on cover clamp.

Type Description	SS	SS (kg)
FTE-50 CC	71352	0,010



Cover Clip FTE80

Quick and easy clip-on cover clamp.

Type Description	SS	SS (kg)
FTE-80 CC	71459	0,020



Cover Fixing Clamp FTE50

Cover fixing clamp for use in high winds or for covers with width exceeding 300mm.

Produced in FRP.

Type Description	FRP	FRP (kg)
FTE-50 CC-HD-50	73930	0,20
FTE-50 CC-HD-100	73931	0,30
FTE-50 CC-HD-150	73929	0,30
FTE-50 CC-HD-200	73932	0,40
FTE-50 CC-HD-300	73933	0,50
FTE-50 CC-HD-400	71491	0,60
FTE-50 CC-HD-600	71563	0,90



Cover Fixing Clamp FTE80

Cover fixing clamp for use in high winds or for covers with width exceeding 300mm.

Produced in FRP.

Type Description	FRP	FRP (kg)
FTE-80 CC-HD-50	73934	0,20
FTE-80 CC-HD-100	73935	0,30
FTE-80 CC-HD-150	73938	0,30
FTE-80 CC-HD-200	73936	0,40
FTE-80 CC-HD-300	73937	0,50
FTE-80 CC-HD-400	71497	0,60
FTE-80 CC-HD-500	72116	0,80
FTE-80 CC-HD-600	73908	0,90



Ventilated Cover Clamp FTE

Raised Cover Clamp for ventilated cover for horizontal fitting with no wind loading.

Type Description	Fasteners included	FRP	FRP (kg)
FTE CC-SV	1xM6	110278	0,070



FTE Accessories

FRP Step Down Splice Plate

Stepped Splice Connector for connecting FTE cable trays in 50 and 80 mm heights.

Type Description	Fasteners included	SS	SS (kg)
FTE-SD-SP-80-50	4xM6	71650	0,090



Hold Down Fixing Clamp

Fixing Clamp for horizontal fixing of both Cable Tray and Cable Ladder systems. Compatible with M10 fasteners.

Type Description	SS	SS (kg)
FTE FC-B47x50	74492	0,040



Fixing Clamp

Fixing Clamp which fits both ladders and trays. Used for vertical or horizontal installations.

Type Description	Fasteners included	SS	SS (kg)	FRP
FOE/FTE FC-B40x65	1xM10	74783	0,040	72024



Smart Jig

With this jig you can pre-drill holes in exact positions when cutting tray lengths on site. Please refer to our recommendations on sealing following cutting and drilling processes.

Type Description	SS	SS (kg)
FTE-DJ 50/80	74397	0,20



Light Fitting Bracket FTE

Light Fitting Bracket suitable for fitting to FTE Cable Trays 100 mm width. Fits all FTE cable tray heights. Allows light to be fitted flat to ground or alternatively at 30° or 45° angle.

Type Description	Fasteners included	SS	SS (kg)
A-FTE LB-100-45/30	-	91107	0,20

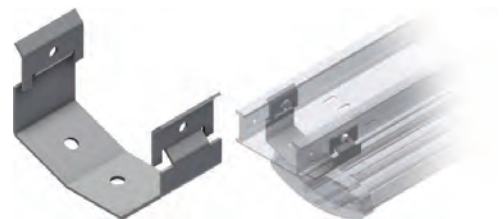



NUTS, BOLTS AND FASTENERS

FLANGE NUTS

Our unique all metal flange nuts stay securely tightened without the need for washers, nylon nuts or thread locking compounds. The key to the system is advanced technology in the thread design, which restricts movement between the nut and bolt during vibration, thus reducing loosening.

Installation time is reduced as the flange nuts are free running onto bolts with no resistance, and are then tightened with one hand and one tool. This also greatly reduces the chance for dropped objects during installation. Furthermore, the flange nut has the washer included which reduces the inventory of parts required. This improves logistics, reduces costs and ensures correct fitment on the bolt.



MATERIALS







SS = A4-70 (Hex A4-80)
FRP = Polyester resin

REFERENCE GUIDE

As a quick reference guide, our best selling fasteners are shown below:



SCREW LIST FOR FRP SUPPORT:

When using SS bolts on FRP supports we recommend a torque of 34 Nm.

	Product Group	Type Description	Material	Where to use	Article number
	Hexagonal Screw	S-M HE-M10x50	A4	Beam Clamp light	1371330
	Hexagonal Screw	S-M HE-M10x30	A4	Most connections	1371327
	Bolt	S-M LS-M10x70	A4	Stringer Bracket crosswise	81396
	Flange Nut	S-M NU-FL-M10	A4	Hexagonal screws: 1371330, 1371327 & 81396	1371973
	Nut & Bolt	S-M PS-M10 x 20	A4	Fixing Clamps	74145

SPECIAL SCREWS FOR FRP PRODUCTS:

Please also study the following page.

	Product Group	Type Description	Material	Where to use	Article number
	Self- Tapping Screw	S-M SE-HE-4.8x13	A2	End Cover	1371373
	Nut & Bolt	S-M PS-M10 x 25	A4	FOE150 and FOE100 Splice Plates	74139
	Nut & Bolt	S-M S-NU-M6 x16	A4	FTE Splice Plates and FOE Cover	74140

FRP Fasteners

FRP Bolt M6

High strength FRP bolt.

Type Description	FRP	FRP (kg)
S-M HE-E-M6x25	75249	0,004



FRP Bolt M10

High strength FRP bolt.

Type Description	FRP	FRP (kg)
S-M HE-E-M10x40	75253	0,010



FRP Nuts

High strength FRP nut.

Type Description	FRP	FRP (kg)
S-M NU-FL-E-M6	73917	0,003
S-M NU-FL-E-M10	71319	-



FRP Stud Bolt M10

Stud bolt for use with FRP support profiles

Type Description	FRP	FRP (kg)
S-M HE-M10 x 30	71487	0,010
S-M HE-M10 x 40	72374	0,010
S-M HE-M10 x 50	71488	0,020
S-M HE-M10 x 80	71489	0,020

1 M10 FRP Nut(s) included.



FRP Sleeve Nut M10

High strength fibre reinforced plastic fasteners with fire retardant vinyl-ester thermoset resin.

Type Description	FRP	FRP (kg)
S-M SN-E-M10	73913	0,020

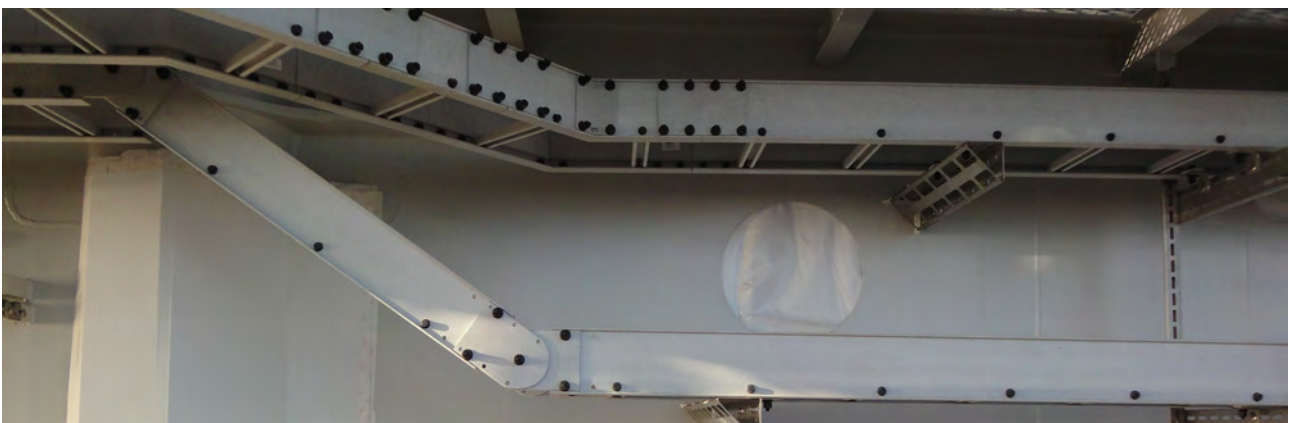

ACCESSORIES

ETIN™ Tubing Clamps

ETIN™ tubing clamps are quick and easy to install and are fully compatible with our standard cable trays and ladders. They are compact in design, and can be stacked and staggered to maximize the fitting space available.

The ETIN™ designs allow quick installation even where access is not available on the back side. The patent protected clamps are independently vibration tested in accordance with DNV standard.



ETIN™ 6-12 mm
(1/4"-1/2")



ETIN™ 14-25 mm
(9/16" - 1")

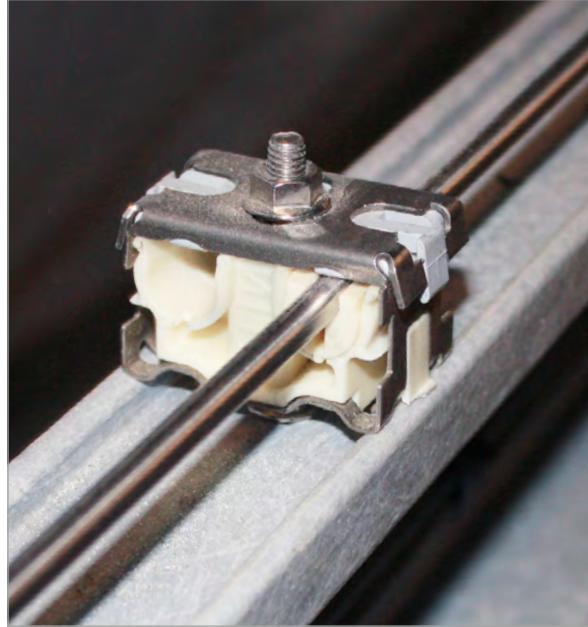

SmartCleat® - short circuit safe cable cleats

SmartCleat® is our range of patented short circuit approved cable cleats which are extremely compact and simple to install on any pre-slotted rung design. The SmartCleat® has been comprehensively tested at Sintef Energy Research Centre in Trondheim, Norway and at IPH Berlin, Germany to IEC 61914 and has a peak loading capacity at 184 kA. In addition, the SmartCleat® is DNV certified to meet the major standards of strength, flexibility and protection.

Our SmartCleat® trefoils are made of stainless steel AISI 316 L with no sharp edges. The cables are held tightly by the smooth surfaces of the cleat ensuring they are not damaged during installation or by a short circuit event. Cleats are available to suit exact cable dimensions and are also supplemented with adapter pads to both extend the application range of the cleat and for when cables may be delivered under dimensioned.



SmartCleat® Single
Ø < 58 mm and 58 - 99 mm



SmartCleat® Trefoil
Ø < 39 mm and 39 - 99 mm



CONTACT

HOLDING COMPANY

Øglænd Industrier AS
Engelsvollvegen 264
NO-4353 Klepp Stasjon, Norway

Phone: +47 51 78 81 00
E-mail: oglaend@oglaend-system.com
www.oglaend-system.com

For more contact information visit:
www.oglaend-system.com/contact

MANUFACTURING COMPANIES

Norway

Øglænd System AS
P: +47 51 78 81 00
E: oglaend@oglaend-system.com

China

Oglaend Industries
(Changzhou) Co., Ltd.
P: + 86 519-80957888

Malaysia

Oglaend Industries Sdn Bhd
P: +60 3 6144 0698
E: sales.MYOGteam@oglaend-system.com

Global Customer Satisfaction

With Superb Supply Chain Performance

Customer focus is one of our core values. As our customers are spread globally we have developed a first class supply chain network, with four production sites and international sales subsidiaries.

This network ensures flexibility and short delivery time to consistently meet and exceed customers expectations and demands.

Oglaend System holds an extensive list of local and international certifications and approvals, such as ISO 9001, ISO 14001 and OHSAS 18001. We have many products and solutions that are patented, registered or trademarked.



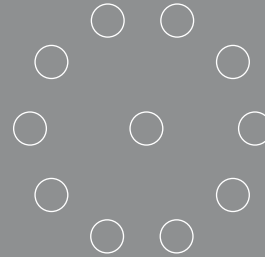
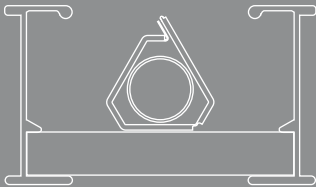
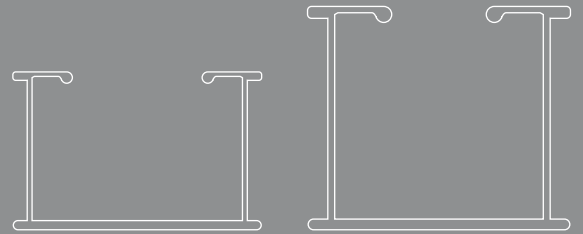

Oglaend System develop, manufacture and sell multidiscipline support solutions, cable trays and cable ladders to the following industries worldwide: Oil & Gas, Infrastructure, Ship building, Wind Energy, Water Treatment, Marine Farming and many other industries.

These solutions deliver added value through reduced installation time, maximized volume utilisation, weight reductions, enhanced lifetime integrity and improved safety performance

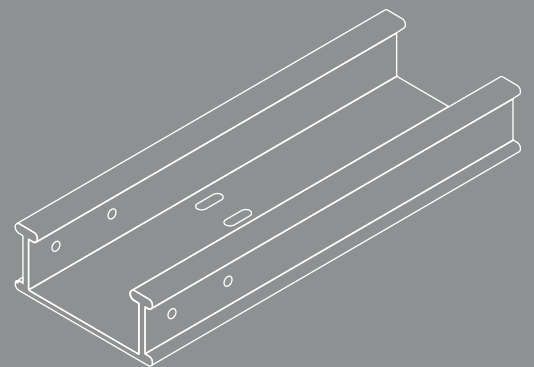
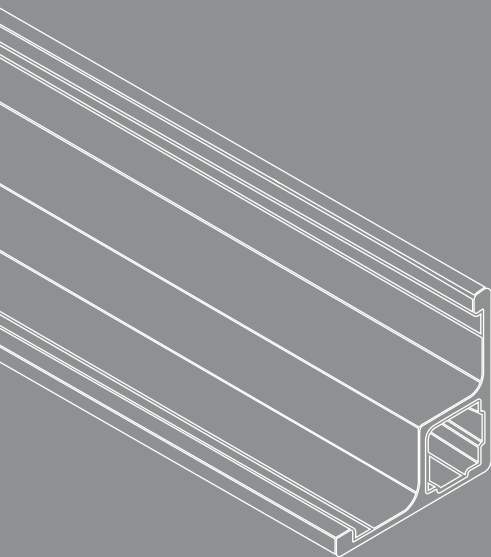
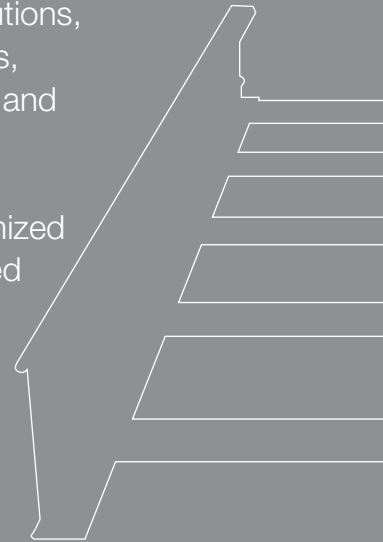

Oglaend System Group (HQ)
Engelsvollvegen 264, 4353 Klepp Stasjon, Norway
Phone: + 47 51 78 81 00
E-mail: oglaend@oglaend-system.com
www.oglaend-system.com

