

INTENDED USE

The CH100S Support Channel is normally fixed back to back without the need of special tools, the end of the profile allows easy access to box-section. When access to box-section is limited, a method involving the use of a sleeve nut is available for fixing the channels back-to-back.

INSTRUCTION FOR USE

Normal Connection

1. Place the drill jig at required location.
2. Use drill jig 87050 to drill required perforations.
3. Clean and tidy perforations.
4. Fasten bolts sets through perforations.

Limited access to box-section: Sleeve nut connection

1. Place the drill jig at required location.
2. Use drill jig 87050 to drill required perforations.
3. Use Granlund drill bit or similar to drill box section for sleeve nut. (Granlund bits: 1F-10,0, 1DS-10 and 1N-20,0)
4. Clean and tidy perforations.
5. Insert sleeve nut through cut out box section.
6. Insert M10 bolt through sleeve from backside of channel.
7. Fasten remaining bolt sets through remaining perforations.



User Guide for Bolts:
Recommended Torque

We recommend a minimum length of 30 mm for bolts.

For more info on use of drill jig see User Guide ØI-RD-UG-EN-0297.

Normal Connection:

Easy access to the channels box-section allows all bolts to be fastened without special tools. For more information on U-frame support see User Guide ØI-RD-UG-EN-0383

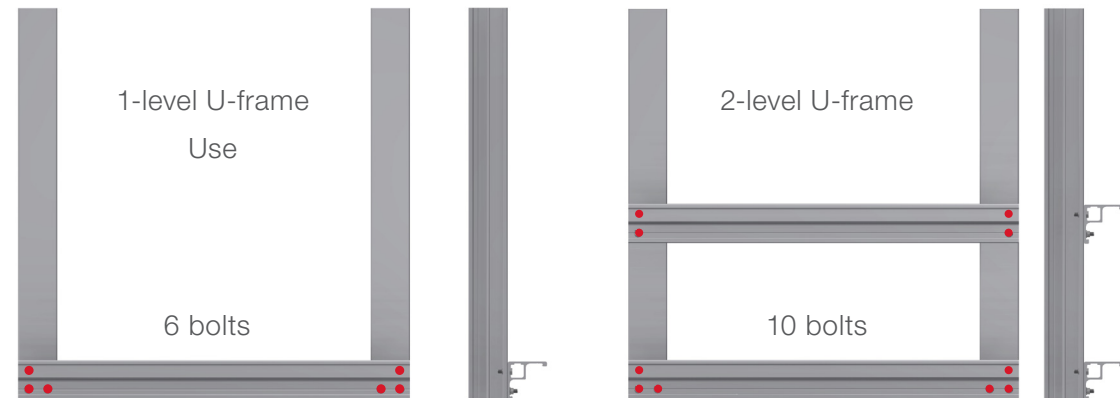

Limited access to box-section: Sleeve Nut Connection

